

**Radio Shack**  
**TRS-80**  
Computer  
Assisted  
Instruction

**Secondary Level  
MATH & SCIENCE  
PROGRAMS**

# TRS-80<sup>®</sup> Chemistry Lab, Volume I Instructor Manual



---

---

TRS-80<sup>®</sup> Chemistry Lab, Volume I is an experiment simulation program that allows students to study laboratory chemistry using a TRS-80 microcomputer. TRS-80 Chemistry Lab, Volume I presents six separate investigations, covering the following topics: Kinetic Theory, Charles' Law, Boyle's Law, Titration, Conductivity, and Solubility. The TRS-80 Chemistry Lab Instructor and Student Manuals include a step-by-step demonstration of how to use the program, plus Background Information, a Summary Quiz, an Experimental Procedure, Data Worksheets, and Conclusions for each of the six investigations. The Instructor Manual also includes Instructional Objectives, the answers to all Quizzes, and Conclusions.

---

---





**THIS WARRANTY SUPERSEDES ALL PRIOR WARRANTIES**

TERMS AND CONDITIONS OF SALE AND LICENSE OF RADIO SHACK COMPUTER EQUIPMENT AND SOFTWARE PURCHASED FROM A RADIO SHACK COMPANY-OWNED COMPUTER CENTER, RETAIL STORE OR FROM A RADIO SHACK FRANCHISEE OR DEALER AT ITS AUTHORIZED LOCATION

**LIMITED WARRANTY**

**I. CUSTOMER OBLIGATIONS**

A. CUSTOMER assumes full responsibility that this Radio Shack computer hardware purchased (the "Equipment"), and any copies of Radio Shack software included with the Equipment or licensed separately (the "Software") meets the specifications, capacity, capabilities, versatility, and other requirements of CUSTOMER.

B. CUSTOMER assumes full responsibility for the condition and effectiveness of the operating environment in which the Equipment and Software are to function, and for its installation.

**II. RADIO SHACK LIMITED WARRANTIES AND CONDITIONS OF SALE**

A. For a period of ninety (90) calendar days from the date of the Radio Shack sales document received upon purchase of the Equipment, RADIO SHACK warrants to the original CUSTOMER that the Equipment and the medium upon which the Software is stored is free from manufacturing defects. THIS WARRANTY IS ONLY APPLICABLE TO PURCHASES OF RADIO SHACK EQUIPMENT BY THE ORIGINAL CUSTOMER FROM RADIO SHACK COMPANY-OWNED COMPUTER CENTERS, RETAIL STORES AND FROM RADIO SHACK FRANCHISEES AND DEALERS AT ITS AUTHORIZED LOCATION. The warranty is void if the Equipment's case or cabinet has been opened, or if the Equipment or Software has been subjected to improper or abnormal use. If a manufacturing defect is discovered during the stated warranty period, the defective Equipment must be returned to a Radio Shack Computer Center, a Radio Shack retail store, participating Radio Shack franchisee or Radio Shack dealer for repair, along with a copy of the sales document or lease agreement. The original CUSTOMER's sole and exclusive remedy in the event of a defect is limited to the correction of the defect by repair, replacement, or refund of the purchase price, at RADIO SHACK'S election and sole expense. RADIO SHACK has no obligation to replace or repair expendable items.

B. RADIO SHACK makes no warranty as to the design, capability, capacity, or suitability for use of the Software, except as provided in this paragraph. Software is licensed on an "AS IS" basis, without warranty. The original CUSTOMER'S exclusive remedy, in the event of a Software manufacturing defect, is its repair or replacement within thirty (30) calendar days of the date of the Radio Shack sales document received upon license of the Software. The defective Software shall be returned to a Radio Shack Computer Center, a Radio Shack retail store, participating Radio Shack franchisee or Radio Shack dealer along with the sales document.

C. Except as provided herein no employee, agent, franchisee, dealer or other person is authorized to give any warranties of any nature on behalf of RADIO SHACK.

D. Except as provided herein, RADIO SHACK MAKES NO WARRANTIES, INCLUDING WARRANTIES OF MERCHANTABILITY OR FITNESS FOR A PARTICULAR PURPOSE.

E. Some states do not allow limitations on how long an implied warranty lasts, so the above limitation(s) may not apply to CUSTOMER.

**III. LIMITATION OF LIABILITY**

A. EXCEPT AS PROVIDED HEREIN, RADIO SHACK SHALL HAVE NO LIABILITY OR RESPONSIBILITY TO CUSTOMER OR ANY OTHER PERSON OR ENTITY WITH RESPECT TO ANY LIABILITY, LOSS OR DAMAGE CAUSED OR ALLEGED TO BE CAUSED DIRECTLY OR INDIRECTLY BY "EQUIPMENT" OR "SOFTWARE" SOLD, LEASED, LICENSED OR FURNISHED BY RADIO SHACK, INCLUDING, BUT NOT LIMITED TO, ANY INTERRUPTION OF SERVICE, LOSS OF BUSINESS OR ANTICIPATORY PROFITS OR CONSEQUENTIAL DAMAGES RESULTING FROM THE USE OR OPERATION OF THE "EQUIPMENT" OR "SOFTWARE." IN NO EVENT SHALL RADIO SHACK BE LIABLE FOR LOSS OF PROFITS, OR ANY INDIRECT, SPECIAL, OR CONSEQUENTIAL DAMAGES ARISING OUT OF ANY BREACH OF THIS WARRANTY OR IN ANY MANNER ARISING OUT OF OR CONNECTED WITH THE SALE, LEASE, LICENSE, USE OR ANTICIPATED USE OF THE "EQUIPMENT" OR "SOFTWARE."

NOTWITHSTANDING THE ABOVE LIMITATIONS AND WARRANTIES, RADIO SHACK'S LIABILITY HEREUNDER FOR DAMAGES INCURRED BY CUSTOMER OR OTHERS SHALL NOT EXCEED THE AMOUNT PAID BY CUSTOMER FOR THE PARTICULAR "EQUIPMENT" OR "SOFTWARE" INVOLVED.

B. RADIO SHACK shall not be liable for any damages caused by delay in delivering or furnishing Equipment and/or Software.

C. No action arising out of any claimed breach of this Warranty or transactions under this Warranty may be brought more than two (2) years after the cause of action has accrued or more than four (4) years after the date of the Radio Shack sales document for the Equipment or Software, whichever first occurs.

D. Some states do not allow the limitation or exclusion of incidental or consequential damages, so the above limitation(s) or exclusion(s) may not apply to CUSTOMER.

**IV. RADIO SHACK SOFTWARE LICENSE**

RADIO SHACK grants to CUSTOMER a non-exclusive, paid-up license to use the RADIO SHACK Software on one computer, subject to the following provisions:

A. Except as otherwise provided in this Software License, applicable copyright laws shall apply to the Software.

B. Title to the medium on which the Software is recorded (cassette and/or diskette) or stored (ROM) is transferred to CUSTOMER, but not title to the Software.

C. CUSTOMER may use Software on one host computer and access that Software through one or more terminals if the Software permits this function.

D. CUSTOMER shall not use, make, manufacture, or reproduce copies of Software except for use on one computer and as is specifically provided in this Software License. Customer is expressly prohibited from disassembling the Software.

E. CUSTOMER is permitted to make additional copies of the Software only for backup or archival purposes or if additional copies are required in the operation of one computer with the Software, but only to the extent the Software allows a backup copy to be made. However, for TRSDOS Software, CUSTOMER is permitted to make a limited number of additional copies for CUSTOMER'S own use.

F. CUSTOMER may resell or distribute unmodified copies of the Software provided CUSTOMER has purchased one copy of the Software for each one sold or distributed. The provisions of this Software License shall also be applicable to third parties receiving copies of the Software from CUSTOMER.

G. All copyright notices shall be retained on all copies of the Software.

**V. APPLICABILITY OF WARRANTY**

A. The terms and conditions of this Warranty are applicable as between RADIO SHACK and CUSTOMER to either a sale of the Equipment and/or Software License to CUSTOMER or to a transaction whereby RADIO SHACK sells or conveys such Equipment to a third party for lease to CUSTOMER.

B. The limitations of liability and Warranty provisions herein shall inure to the benefit of RADIO SHACK, the author, owner and/or licensor of the Software and any manufacturer of the Equipment sold by RADIO SHACK.

**VI. STATE LAW RIGHTS**

The warranties granted herein give the original CUSTOMER specific legal rights, and the original CUSTOMER may have other rights which vary from state to state.





**Radio Shack® TRS-80® Chemistry Lab  
Volume I**

**Instructor Manual**

**Radio Shack®**



A DIVISION OF TANDY CORPORATION  
FORT WORTH, TEXAS 76102



**First Edition**

*TRSDOS™ Operating System:*  
© 1979, 1980, 1981 Tandy Corporation  
*All Rights Reserved.*

*TRS-80® Chemistry Lab, Volume I program:*  
© ©1981, 1982 Richard C. Hallgren  
*All Rights Reserved.*  
*Licensed to Tandy Corporation.*

*"TRS-80® Chemistry Lab, Volume I Instructor Manual"*  
© ©1981, 1982 Richard C. Hallgren  
*All Rights Reserved.*  
*Licensed to Tandy Corporation.*

Reproduction or use, without express written permission from Tandy Corporation, of any portion of this manual is prohibited, except as provided below. While reasonable efforts have been taken in the preparation of this manual to assure its accuracy, Tandy Corporation assumes no liability resulting from any errors or omissions in this manual, or from the use of information obtained herein.

The Data Worksheets, pages 37, 50, 64, 78, 88, and 100, may be reproduced as necessary without written permission from Tandy Corporation or Richard C. Hallgren.

Please refer to the Software License in the front of this manual for limitations on use and reproduction of this Software package.

# Table of Contents

Introduction .....	1
User's Guide .....	3
The TRS-80 Model III Computer.....	5
The TRS-80 Color Computer.....	6
Special Keys and Features .....	7
Loading the Model III TRS-80 Chemistry Lab, Volume I...	8
Using the Model III Computer Tape System.....	8
Using the Model III Computer Disk System .....	9
Loading the Color Computer TRS-80 Chemistry Lab, Volume I.....	10
How to Use the TRS-80 Chemistry Lab, Volume I.....	11
For the TRS-80 Models III and I .....	11
For the TRS-80 Color Computer.....	16
Investigations.....	23
Kinetic Theory .....	25
Instructional Objectives.....	27
Background Information.....	29
Summary Quiz .....	33
Experimental Procedure .....	34
Data Worksheets.....	35
Conclusions.....	38
Charles' Law .....	39
Instructional Objectives.....	41
Background Information.....	43
Summary Quiz .....	46
Experimental Procedure .....	47
Data Worksheets.....	48
Conclusions.....	51



<b>Boyle's Law</b> .....	<b>53</b>
<b>Instructional Objectives</b> .....	<b>55</b>
<b>Background Information</b> .....	<b>57</b>
<b>Summary Quiz</b> .....	<b>60</b>
<b>Experimental Procedure</b> .....	<b>61</b>
<b>Data Worksheets</b> .....	<b>62</b>
<b>Conclusions</b> .....	<b>65</b>
<b>Conductivity</b> .....	<b>67</b>
<b>Instructional Objectives</b> .....	<b>69</b>
<b>Background Information</b> .....	<b>71</b>
<b>Summary Quiz</b> .....	<b>74</b>
<b>Experimental Procedure</b> .....	<b>75</b>
<b>Data Worksheets</b> .....	<b>76</b>
<b>Conclusions</b> .....	<b>79</b>
<b>Solubility</b> .....	<b>81</b>
<b>Instructional Objectives</b> .....	<b>83</b>
<b>Background Information</b> .....	<b>85</b>
<b>Summary Quiz</b> .....	<b>86</b>
<b>Experimental Procedure</b> .....	<b>87</b>
<b>Data Worksheets</b> .....	<b>88</b>
<b>Conclusions</b> .....	<b>89</b>
<b>Titration</b> .....	<b>91</b>
<b>Instructional Objectives</b> .....	<b>93</b>
<b>Background Information</b> .....	<b>95</b>
<b>Summary Quiz</b> .....	<b>97</b>
<b>Experimental Procedure</b> .....	<b>98</b>
<b>Data Worksheets</b> .....	<b>99</b>
<b>Conclusions</b> .....	<b>101</b>
<b>Appendices</b> .....	<b>103</b>
<b>Appendix I: Making a Backup Copy of the</b> <b>Model III TRS-80 Chemistry Lab,</b> <b>Volume I Diskette</b> .....	<b>105</b>

<b>Appendix II: Making a Backup Copy of the Model III, Model I or Color Computer TRS-80 Chemistry Lab, Volume I Tape.....</b>	<b>109</b>
<b>Appendix III: Planning Your Application .....</b>	<b>111</b>
<b>Appendix IV: Special Information for</b>	
<b>TRS-80 Model I Users .....</b>	<b>115</b>
<b>How to Get the Model I Software .....</b>	<b>117</b>
<b>Loading the Model I TRS-80 Chemistry Lab,         Volume I .....</b>	<b>118</b>
<b>Making a Backup Copy of the         Model I TRS-80 Chemistry Lab,         Volume I Diskette .....</b>	<b>120</b>



# INTRODUCTION

TRS-80® Chemistry Lab, Volume I is a laboratory simulation program which was designed to be used on the TRS-80 Models III or I, or on the Color Computer, as a supplement to classroom instruction. The mathematical equations used by the computer in these simulations are derived from real experiments which took place in an analytical laboratory. By using the computer, junior high and high school students will be able to investigate a variety of situations without special laboratory equipment.

The TRS-80 Chemistry Lab, Volume I Instructor Manual is divided into two main sections:

- User's Guide
- Investigations.

The "User's Guide" provides information on how to use TRS-80 Chemistry Lab, Volume I, including a step-by-step demonstration of how to progress through a chemistry lab. The "Investigations" section gives the Instructional Objectives, Background Material, Summary Quiz, Experimental Procedure, Data Worksheets, and Conclusions for the following laboratory simulations:

- Kinetic Theory
- Charles' Law
- Boyle's Law
- Conductivity
- Solubility
- Titration.

TRS-80 Chemistry Lab, Volume I can be used with the following systems:

- TRS-80 Model III (with Model III BASIC) 16K tape system\*
- TRS-80 Model III (with Model III BASIC) 32K or 48K disk system\*
- TRS-80 Model I (with Level II BASIC) 16K tape system\*
- TRS-80 Model I (with Level II BASIC) 32K or 48K disk system\*
- TRS-80 Color Computer (with Extended BASIC) 16K tape system\*\*
- a Radio Shack Network System, which can support up to 16 student stations with a single central TRS-80 disk system.

Additional Student Experiment Books are available separately from Radio Shack (Catalog Number 26-2666).

\*The Model III/(Model I available) version of TRS-80 Chemistry Lab, Volume I (Cat. No. 26-2609) contains a diskette for use with the Model III 32K or 48K disk system, and a 1500 Baud cassette tape for use with the Model III 16K tape system. Appendix IV of this manual tells how to get free replacement software to use with the Model I disk and/or tape system.

\*\*The Color Computer version of TRS-80 Chemistry Lab, Volume I is Catalog Number 26-2626.





## **USER'S GUIDE**





# THE TRS-80 MODEL III COMPUTER

Before loading the TRS-80 Chemistry Lab, Volume I program into the TRS-80 Microcomputer, take a moment to familiarize yourself with the computer. Here are the major components you'll need to know:

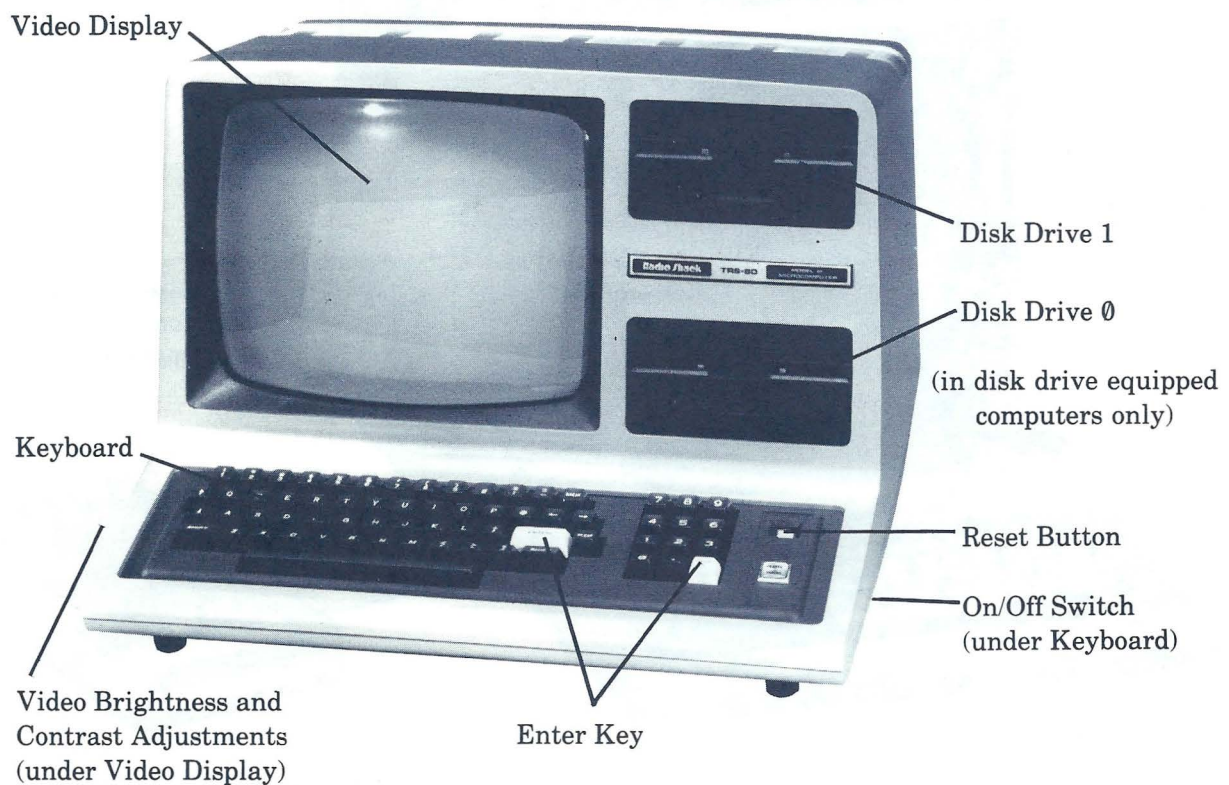

**Note:** If you are setting up your TRS-80 Microcomputer for the first time, refer to the user's manual packed with each TRS-80 system for instructions.

Before you load your program, let's take a moment to review some special keys and features.

# THE TRS-80 COLOR COMPUTER

TRS-80 13" Color Video Receiver  
*or*  
Any Color TV

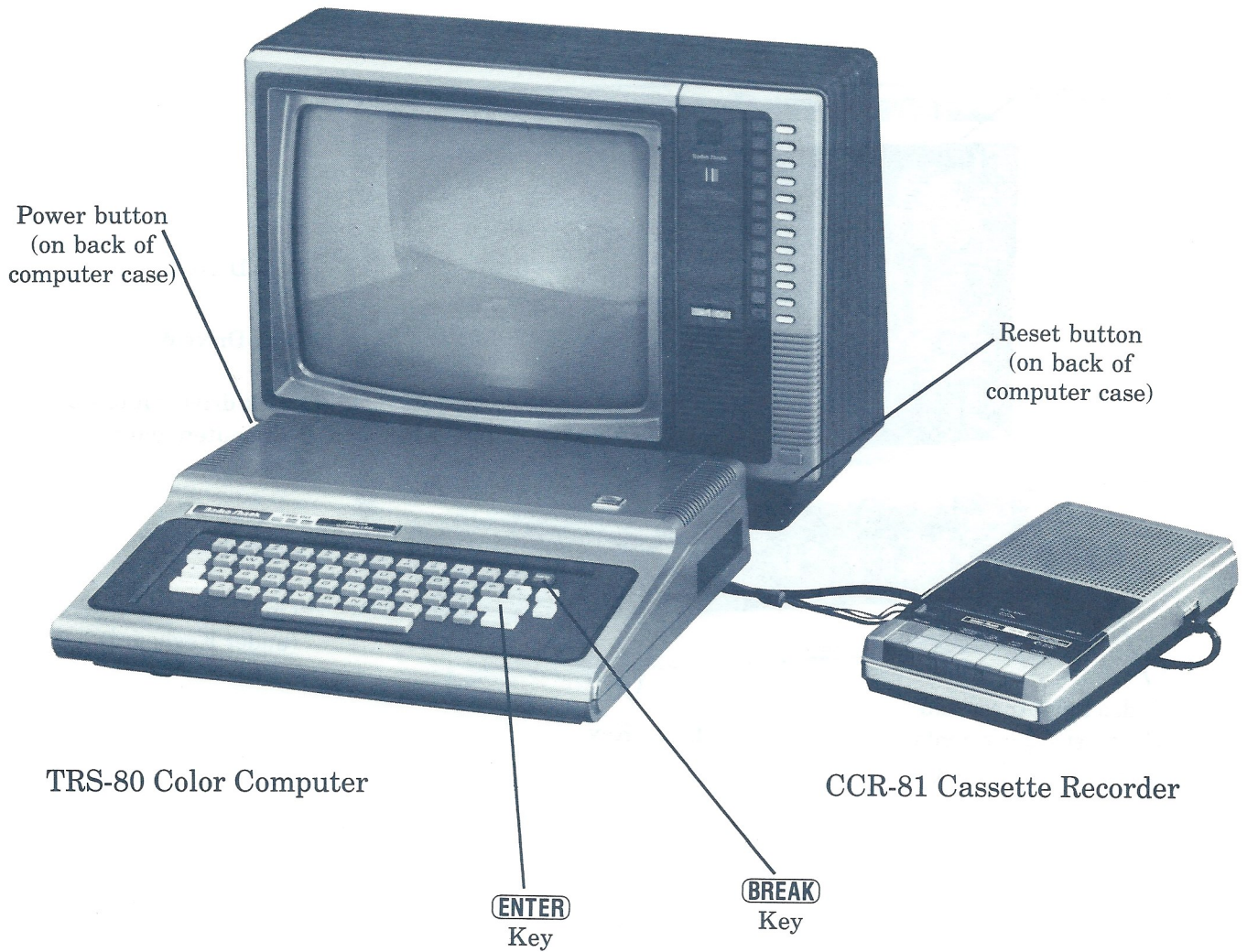

## SPECIAL KEYS AND FEATURES

### READY



The "READY prompt" appears on the TRS-80 Model III and I screen whenever the computer is waiting for a command (for example,

**R U N " K I N E T I C "**).



### ENTER

This key is used to "enter" information into the computer. Once you have loaded the TRS-80 Chemistry Lab, Volume I program that you want to work with, the **ENTER** key is used to continue to the next screen in the program.



### SHIFT T

At any screen except the initial copyright screen or the first screen of an experiment, pressing **T** while holding down the **SHIFT** key causes the program to terminate and the READY prompt to reappear. (To run the same program again, type **R U N** and press **ENTER**. See page 15 or 22 for how to run a different program.)



The "up-arrow" and "down-arrow" keys are used to control the variables of the experiment. (For example, the  key is used in Kinetic Theory to add gas to the cylinder, and the  and  keys are then used to increase and decrease the temperature of the gas.)



The "left-arrow" key can be used to erase characters when typing information onto the screen before you press **ENTER**. Each press of the  key erases one space to the left. The  key is also used to return to a previous screen when instructions on the screen indicate that this option is available.



The **L** key is used to return to the laboratory simulation screen. This option is only available when it is indicated on the screen.



The **S** key is used to store data points in the computer's memory during the simulations.

### BREAK

If you are using the Color Computer, avoid pressing the **BREAK** key while running a program. Pressing **BREAK** will terminate the program and return you to the READY prompt. At the READY prompt, you can start the program again by typing **R U N** and pressing **ENTER**.



# LOADING THE MODEL III TRS-80 CHEMISTRY LAB, VOLUME I

To load the Chemistry Lab, Volume I program into the computer, follow the steps below in exact order:

## Using the Model III Computer Tape System

1. Turn on the computer. (The On/Off switch is under the right side of the keyboard).
2. Place the Model III program cassette that you want to use in the cassette recorder. For this demonstration, use the cassette labeled "Kinetic Theory."
3. Set the volume level of the cassette recorder between 5 and 7.
4. Press "REWIND." When the cassette is rewound, press "STOP," then press "PLAY."
5. When **Cass?** appears on the video display, press **(H)**.
6. When **Memory Size?** appears on the video display, press **(ENTER)**.
7. Type **(C)(L)(O)(A)(D)** and press **(ENTER)**. (If the program is loading properly, two asterisks will appear in the upper right corner of the screen. The right asterisk will blink.)\*
8. When the **READY** prompt appears on the screen, press the "STOP" button, then press "REWIND" to rewind the tape on the recorder. Next, remove the tape and replace it in the cassette holder to protect it from damage.
9. Type **(R)(U)(N)** and press **(ENTER)**. You'll see the title screen appear on the video display.

To begin working with Kinetic Theory, turn to page 11.

\* If the asterisks do not appear after several seconds:

- press "STOP"
- turn the volume a little higher
- press the orange Reset button
- repeat the instructions from Step 4.

If the asterisks appear, but the right one does not blink:

- press "STOP"
- turn the volume a little lower
- press the orange Reset button
- repeat the instructions from Step 4.

## Using the Model III Computer Disk System

1. Turn on the computer. (The On/Off switch is under the right side of the keyboard.)
2. When the red light goes off, insert the program diskette in Drive 0 (the bottom disk drive) with the square notch to the left and the label facing up, and close the door.
3. Press the orange Reset button.
4. Type the date, being sure to use two digits each for the month, day, and year, with a slash separating each pair. (Example: 09/01/83 for September 1, 1983.) Then press **ENTER**.
5. When asked for the time, simply press **ENTER**.
6. When **TRSDOS Ready** appears on the screen, type **BASIC ENTER**.
7. When **How Many Files?** appears on the screen, press **ENTER**. When **Memory Size?** appears on the screen, press **ENTER** again.
8. When the **READY** prompt appears, type **RUN "KINETIC"** and press **ENTER**. You'll see the title screen appear on the video display.

**NOTE:** The disk filenames of all the programs in TRS-80 Chemistry Lab, Volume I are as follows (these names can be found printed on the label of the program diskette):

Filename:	Program:
<b>KINETIC</b>	Kinetic Theory
<b>CHARLES</b>	Charles' Law
<b>BOYLES</b>	Boyle's Law
<b>CONDUCT</b>	Conductivity
<b>SOLUBIL</b>	Solubility
<b>TITRATE</b>	Titration

To run the Charles' Law program, for example, enter **RUN "CHARLES"** at the **READY** prompt.

To begin working with Kinetic Theory, turn to page 11.



## LOADING THE COLOR COMPUTER TRS-80 CHEMISTRY LAB, VOLUME I

**NOTE:** If you have a 16K Color Computer which you also use in a disk system, you will need to disconnect the Color Computer Disk Controller from the computer before you can load this tape program.

Set up and connect the Color Computer, color video receiver or TV, and cassette recorder according to the instructions in the TRS-80 Color Computer Operation Manual. Then follow the steps below:

1. Turn on the color video receiver or TV, and turn the volume all the way down. Select channel 3 or 4 (whichever is weaker or not used in your area). Select the same channel on the "channel select" switch at the rear of your computer.
2. Turn on the computer by pushing in the power button on the back left of the computer case. You'll see an "OK" prompt appear on the video screen.
3. Place a Chemistry Lab tape in the cassette recorder (for this demonstration, use the tape labeled "Kinetic Theory.")
4. Set the volume level of the cassette recorder between 5 and 7.
5. Rewind the tape completely. After the tape is completely rewound, press the cassette recorder's "PLAY" button.
6. Type **C L O A D** at the keyboard and press **ENTER**. While the computer searches for the program, the letter "S" will be displayed in the upper left of the video screen. When the computer finds the program, the letter "F" followed by the name of the program will appear.
7. When the "OK" prompt reappears, type **R U N** and press **ENTER**.

**NOTE:** If you should get an error message while loading your Chemistry Lab program, the volume on the cassette recorder could be too low or too high. You should:

- press the "STOP" button on the cassette recorder.
- turn the volume a little higher or a little lower.
- press the Reset button on the back of the computer.
- repeat the instructions from Step 5 above.

Should consistent loading problems develop, take your cassette recorder to your local Radio Shack store or Computer Center for proper balance, azimuth alignment, and cleaning.

# HOW TO USE THE TRS-80 CHEMISTRY LAB, VOLUME I FOR THE TRS-80 MODELS III AND I

To begin this demonstration, follow the instructions on page 8, 9, or 118 to load Kinetic Theory into your TRS-80 Model III or Model I. Once Kinetic Theory is loaded, you'll see the title screen. After a short pause, a screen describing the kinetic theory appears:

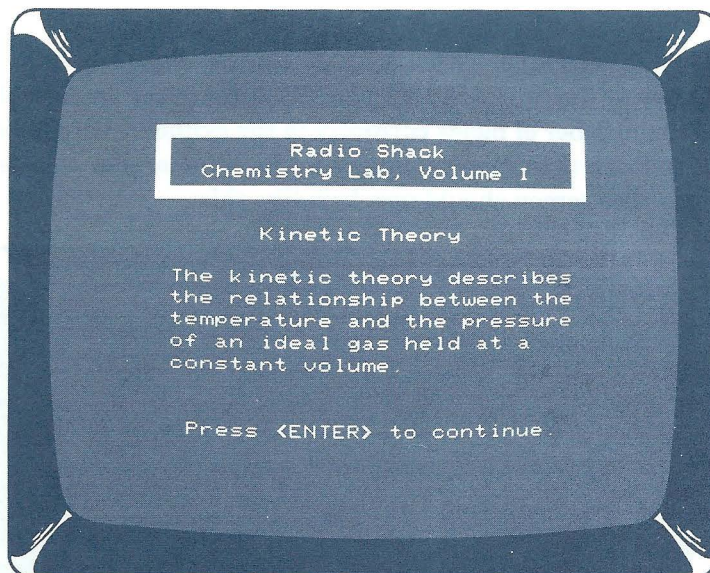

Read the screen carefully, then press **ENTER** to continue. The next few screens will further explain the kinetic theory and the laboratory experiment; press **ENTER** to continue after reading each screen. When you come to Part 1 of the experiment, you will see this screen:

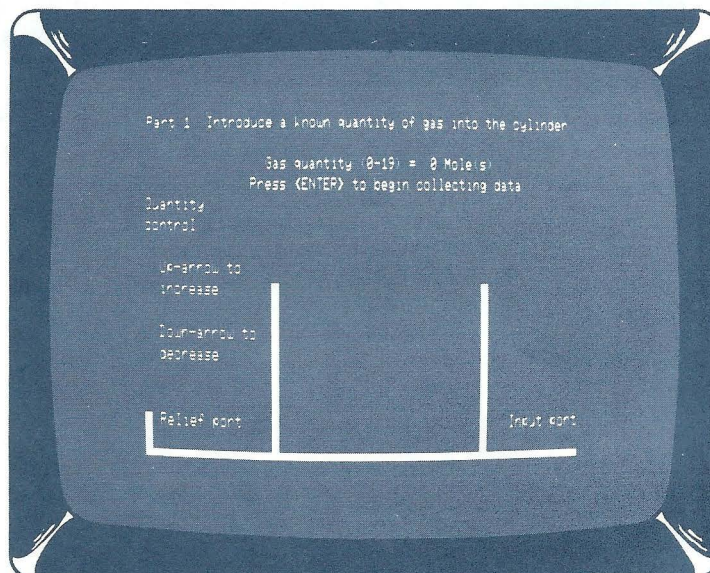



Begin by introducing a known quantity of gas into the cylinder. The display on the screen graphically represents a cylinder connected to an input port and a relief port. The input port transfers gas into the cylinder when you want to increase the quantity of gas; the relief port transfers gas out of the cylinder when you want to decrease the quantity of gas.

Since the cylinder is empty to begin with, press the  $\uparrow$  key on your keyboard once to add one mole of gas. Notice that the line above the cylinder now reads:

**Gas quantity (0 - 19) = 1 Mole(s)**

As you press the  $\uparrow$  key or the  $\downarrow$  key to increase or decrease the amount of gas, this line will continue to indicate the number of moles currently in the cylinder. Remember that you must put at least one and no more than nineteen moles in the cylinder. For this demonstration, try adding 10 moles of gas. The screen should now look like this:

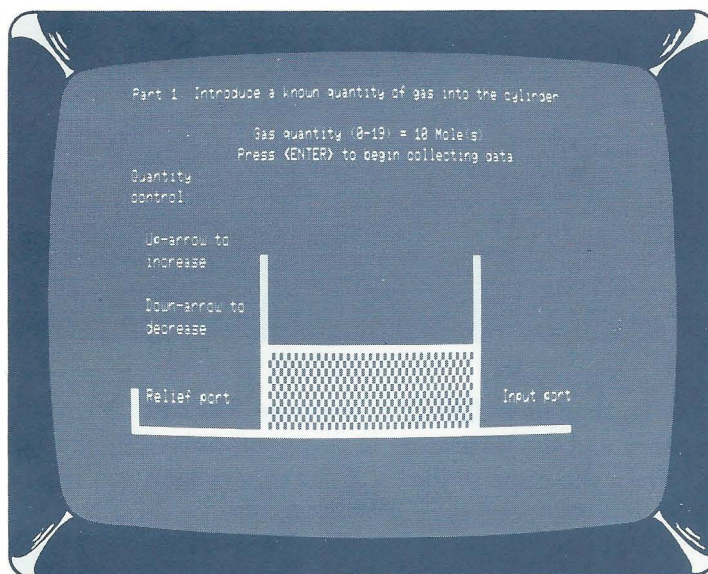

Now record the amount of gas in the cylinder (10 moles) on your Data Worksheet for Kinetic Theory (page 37). Then press **(ENTER)** to "begin collecting data" (Part 2 of the experiment). The following screen will appear:



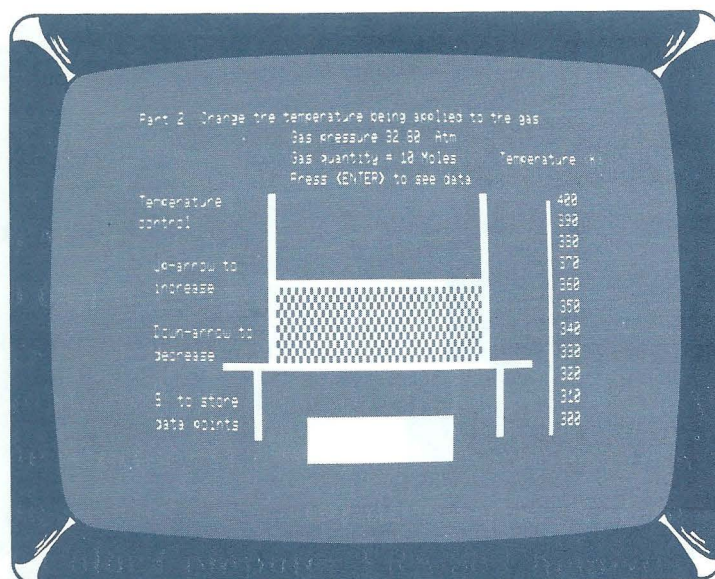

Notice that the quantity of gas in the cylinder is displayed in the area above the cylinder. Note also that the temperature (T) and the pressure (P) of the gas are displayed on the screen. The temperature of the gas will initially be 400 degrees Kelvin. You will be able to decrease or increase the temperature by using the  $\downarrow$  and the  $\uparrow$  keys on your keyboard. As you move the temperature down, notice the relationship between the temperature and the pressure of the gas.

You are now ready to plot the pressure of the gas as a function of the temperature of the gas. To do this, you must store the data points at each change of temperature by pressing **S** at each temperature change. Using the  $\downarrow$  and  $\uparrow$  keys, move the temperature gauge through ten different increments, stopping to press **S** at each change of temperature to store the data point. Notice that check marks appear next to the temperature gauge to indicate which data points have been stored in the computer's memory. (Before you continue, be sure that a check mark, or an asterisk if you are using the Model I, is displayed for each data point you want.) As you store the data for each increment, be sure to record the magnitude of the pressure at each point on your worksheet. When you are finished storing the data points, the screen should look similar to this:

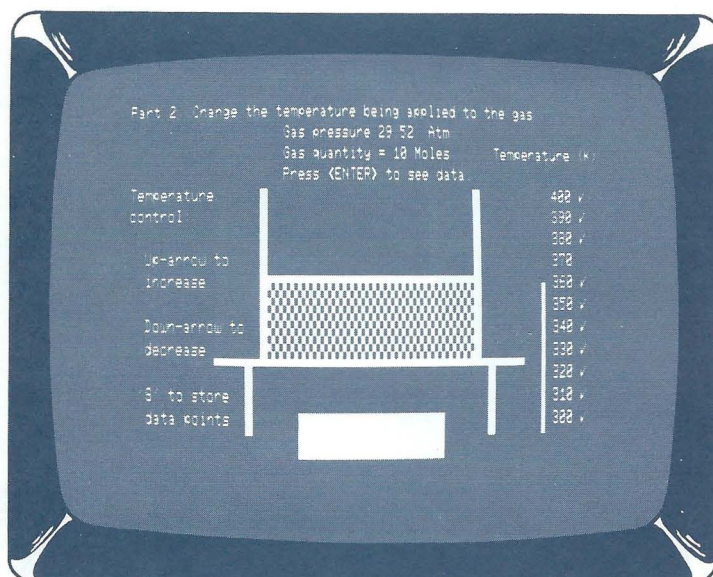

After collecting all ten data points, press **(ENTER)** to see the DATA TABLE:

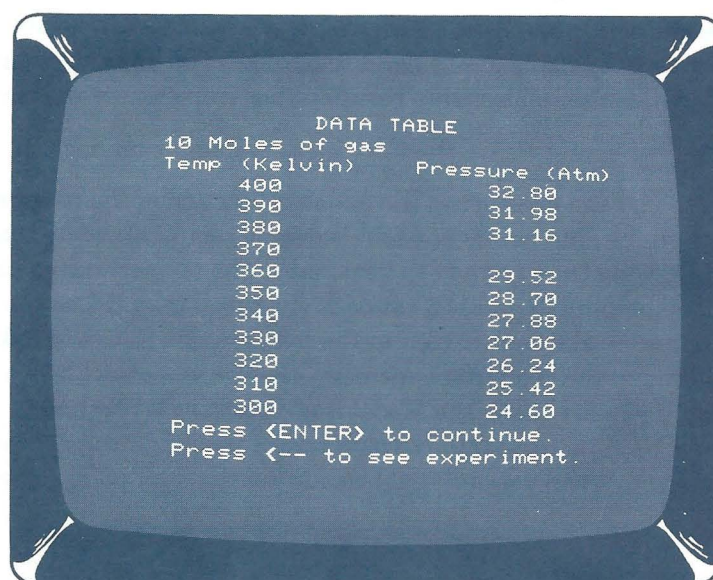

Record the displayed data on your worksheet, and then plot the pressure associated with each temperature. Since the pressure will be a function of the quantity of gas that you placed in the cylinder, you will need to scale the y axis. See page 36 for the appropriate y axis values for each quantity of gas. (For this demonstration, use the values under the column that is headed "10" for 10 moles of gas.)

**Note:** Each investigation provides a sample data worksheet and, when applicable, a list of the scaling factors for completing your own graphs. The columns of values given for scaling should be marked on the graph so that the bottom number (also the lowest value) indicates the bottom line on the graph and the top number (the highest value) marks the top line of the graph.



When you have finished plotting the ten data points on your worksheet, connect the points to form a smooth curve. Next press **(ENTER)** on the keyboard to have the computer plot the data points that you stored. The screen will look like this:

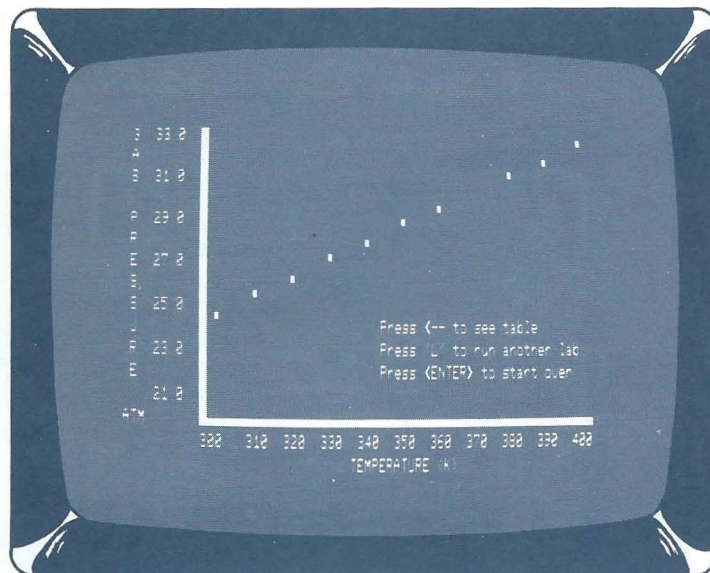

The curve on your worksheet should look similar to the plotted data displayed on the screen.

Note that the screen also displays three options. Pressing the left-arrow key (**(←)**) will return you to the Data Table. Pressing **(L)** will return you to the screen display for Part 1 of the Kinetic Theory lab, where you can begin the procedure again, choosing a new quantity of gas for a new set of data. Pressing **(ENTER)** will return you to the beginning of the Kinetic Theory program.

If you want to run a different program after you have reviewed the plotted data on the screen, you can press **(SHIFT)(T)** to end the Kinetic Theory program. When the **READY** prompt appears, type **(R)(U)(N)** followed by the name of the program in quotation marks; then press **(ENTER)**. For example: **(R)(U)(N)(“(B)(O)(Y)(L)(E)(S)”(ENTER))**.

# HOW TO USE THE TRS-80 CHEMISTRY LAB, VOLUME 1 FOR THE TRS-80 COLOR COMPUTER

To begin this demonstration, follow the instructions on page 10 to load Kinetic Theory into your Color Computer. Once Kinetic Theory is loaded, you'll see the title screen. After a short pause, a screen describing the kinetic theory appears:

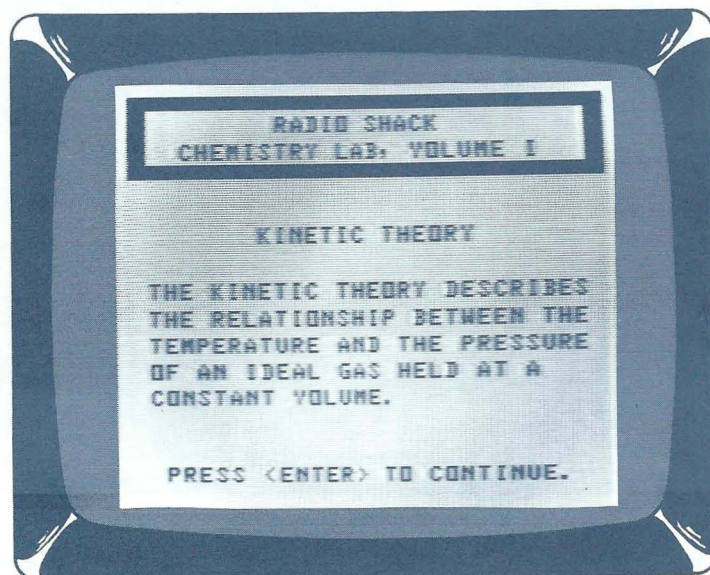

Read the screen carefully and press **(ENTER)** to continue. The next few screens will further explain the kinetic theory and the laboratory experiment; press **(ENTER)** to continue after reading each screen. When you come to the instruction screen for Part 1 of the experiment, you will see:

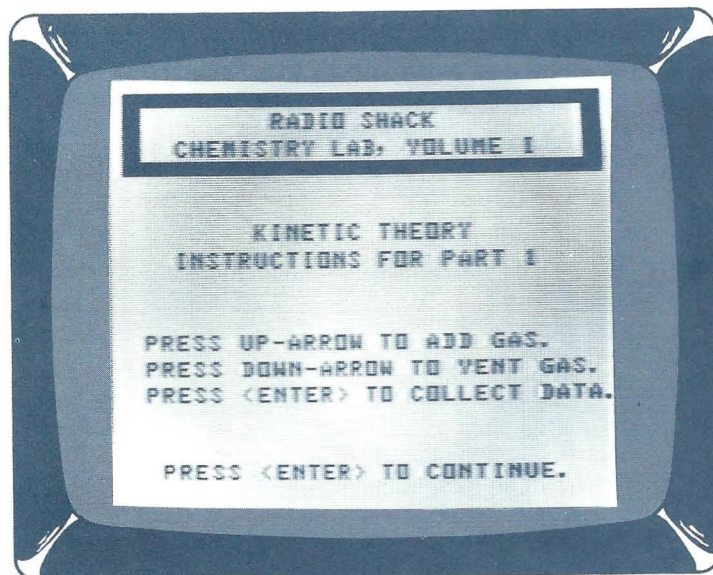



This screen provides the instructions for the simulation screen to follow. Read these instructions carefully and then press **(ENTER)**. The Part 1 simulation screen will appear:

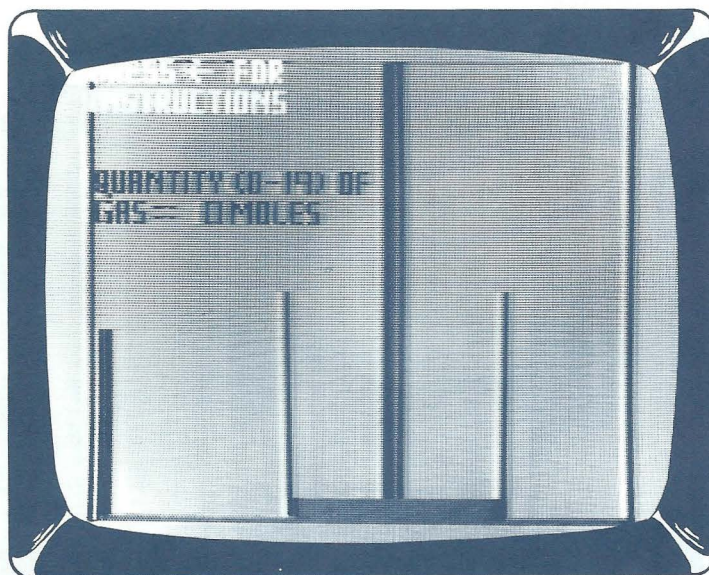

Begin by introducing a known quantity of gas into the cylinder. The display on this screen represents a cylinder connected to an input port and a relief port. The input port transfers gas into the cylinder when you want to increase the quantity of gas; the relief port transfers gas out of the cylinder when you want to decrease the quantity of gas.

Since the cylinder is empty to begin with, press the **(↑)** key on your keyboard to add one mole of gas. Notice that the line above the cylinder now reads:

**QUANTITY (0 - 19) OF  
GAS = 1 MOLE(S)**



As you press the  $\uparrow$  key or the  $\downarrow$  key to increase or decrease the amount of gas, this line will continue to indicate the number of moles currently in the cylinder. Remember that you must put at least one and no more than nineteen moles in the cylinder. For this demonstration, try adding 10 moles of gas. The screen should now look like this:

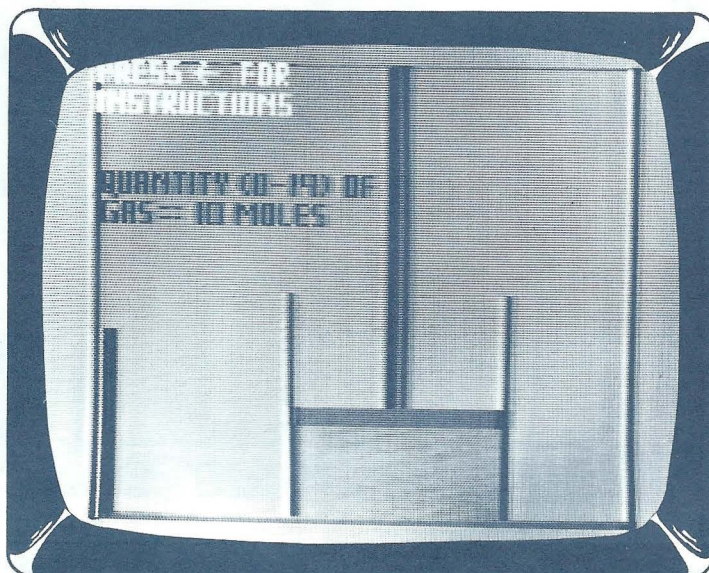

Now record the amount of gas in the cylinder (10 moles) on your Data Worksheet for Kinetic Theory (page 37). Then press **ENTER** to continue to Part 2. The following screen will appear:

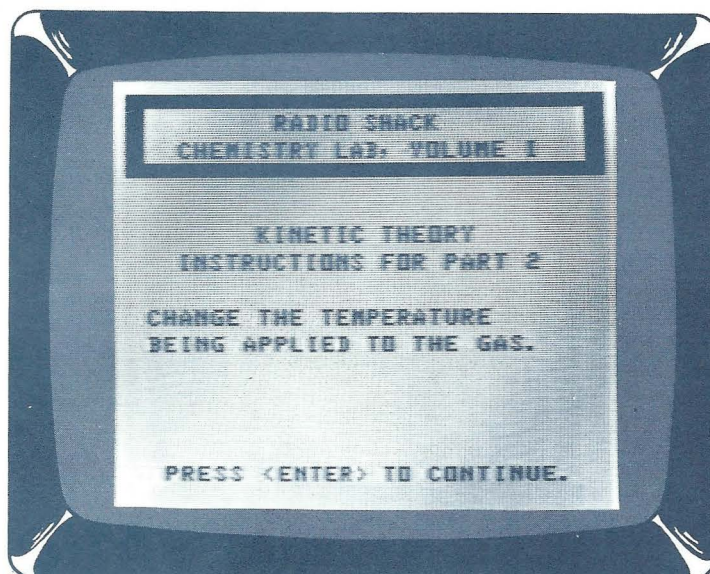

Read the instructions for Part 2 and press **(ENTER)**. Continue through two more instruction screens, reading the instructions carefully. When you are ready to perform the second part of the experiment, press **(ENTER)** and the simulation screen will appear:

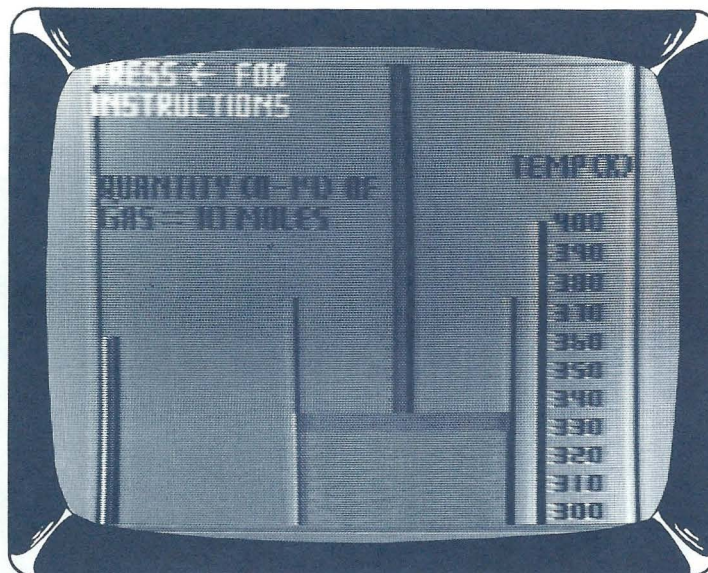

Notice that the quantity of gas you introduced into the cylinder is displayed on the screen. The temperature of the gas will initially be 400 degrees Kelvin.

**Note:** If you have forgotten the instructions on the previous screens at this point in the program, press the **(↑)** key to review them. Then return to Part 2 of the simulation.

You will be able to decrease or increase the temperature by using the **(↓)** and the **(↑)** keys on your keyboard. Since the temperature is set at 400, begin by pressing the **(↓)** key. As you move the temperature down, notice the relationship between the temperature and the pressure of the gas.



You are now ready to plot the pressure of the gas as a function of the temperature of the gas. To do this, you must store the data points at each change of temperature. Using the  $\downarrow$  and  $\uparrow$  keys, move the temperature gauge through ten different increments, stopping to press  $\$$  at each change of temperature to store the data point. Notice that check marks appear next to the temperature gauge, to indicate which data points have been stored in the computer's memory. (Before you continue, be sure that a check mark is displayed for each data point you want.) When you are finished storing the data points, the screen should look similar to this:



After collecting all ten data points, press  $\text{ENTER}$  to see the DATA TABLE:

DATA TABLE	
10 MOLES OF GAS	
TEMP (KELVIN)	PRESSURE (ATM)
400	
390	31.98
380	31.16
370	30.34
360	29.52
350	28.70
340	27.88
330	27.06
320	26.24
310	25.42
300	24.60

PRESS  $\text{ENTER}$  TO CONTINUE.  
PRESS  $\leftarrow$  TO SEE EXPERIMENT.

Record the displayed data on your worksheet, and then plot the pressure associated with each temperature. Since the pressure will be a function of the quantity of gas that you placed in the cylinder, you will need to scale the y axis. See page 36 for the appropriate y axis values for each quantity of gas. (For this demonstration, use the values under the column that is headed "10" for 10 moles of gas.)



**Note:** Each investigation provides a sample data worksheet and, when applicable, a list of the scaling factors for completing your own graphs. The columns of values given for scaling should be marked on the graph so that the bottom number (also the lowest value) indicates the bottom line on the graph and the top number (the highest value) marks the top line of the graph.

When you have finished plotting the ten data points on your worksheet, connect the points to form a smooth curve. Next press **(ENTER)** on the keyboard to have the computer plot the data points that you stored. The screen will look like this:

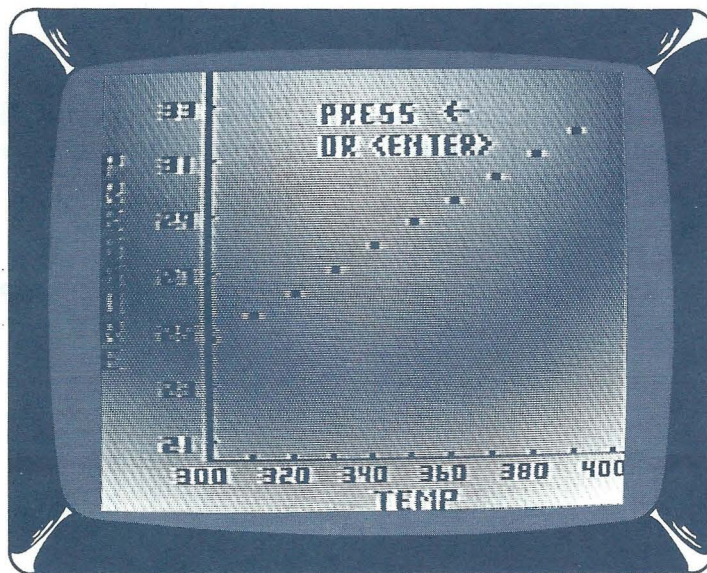

The curve on your worksheet should look similar to the plotted data displayed on the screen.

When you have finished viewing the plotted data on the screen, you can either press the **(←)** key to see the DATA TABLE again, or you can press **(ENTER)** to get a list of other options. For this demonstration, let's press **(ENTER)**. The following will appear on your screen:

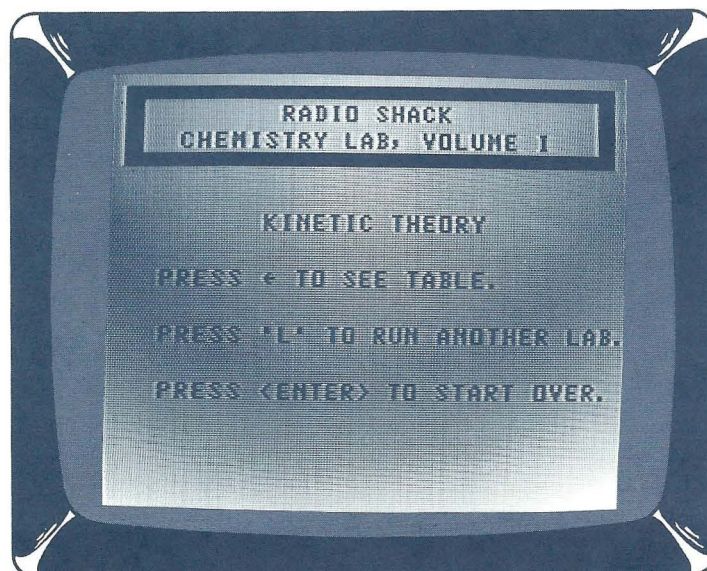



At this point in the program, you have three choices: You can press  $\leftarrow$  to return to the DATA TABLE to review the data and the graph of the data for the experiment you just completed. Or you can press **ENTER** to go back to the title screen of the program and start again. Or you can press **L** to perform another experiment, using a different quantity of gas to collect a new set of data.

**Note:** The **L** key returns you to the Part 1 instructions screen without repeating the beginning explanation screens. When you complete Part 1 and press **ENTER** to continue to Part 2, you will see the Part 2 lab screen immediately (you'll skip past the Part 2 instructions screens). The **L** key provides a shortcut for those who have already performed the experiment and do not need to review the instructions each time they gather additional data.

To end the program when you are finished working with it, hold down the **SHIFT** key as you type **T**. You'll see a copyright screen with the "OK" prompt displayed. To start the program again from this screen, type **RUN** and press **ENTER**.

To change to a different program, rewind the cassette tape completely; then remove it from the cassette recorder and store it in a safe place. Choose a different program tape, then follow the steps on page 10.

## **INVESTIGATIONS**



## **Kinetic Theory**

**The relationship between the temperature and the pressure of an ideal gas at constant volume.**





## **Kinetic Theory Instructional Objectives**

After completing this unit, students will be able to:

1. Explain the kinetic theory.
2. Experimentally determine the relationship between the temperature and the pressure of an ideal gas held in a constant volume container.
3. Define the Kelvin temperature scale.





## Kinetic Theory Background Information

The kinetic theory is concerned with explaining the motion of particles and the parameters that influence this motion. The kinetic theory contains many postulates, but the ones which pertain to this investigation are the following:

1. A gas is composed of molecules which will expand to fill any container into which it is placed. The molecules will only sparsely populate the total volume of the container.
2. The gas molecules are in constant motion, colliding frequently with each other and with the walls of the container.
3. In an ideal gas, there will be no loss in momentum as a result of the collisions; this indicates that the collisions are assumed to be completely elastic.

Explain that an "ideal" gas is one in which the gas molecules do not interact with each other except in elastic collisions.

4. Gas pressure results from the repeated collision of the gas molecules with the walls of the container. The force and frequency of these collisions is determined by the average kinetic energy of the molecules, which is directly related to the temperature of the gas.

Since the gas law simulations all build upon these assumptions, you may want to spend some additional time on them if the material has not previously been covered.

Based upon these postulates, we would expect the pressure exerted by a gas to increase as the temperature of the gas is increased.

Whether or not students understand and agree with this statement is a good measure of their comprehension of the material discussed so far.

It is known that if the temperature of a gas is increased, the gas molecules will move with increased average velocity, resulting in a net increase in the average kinetic energy of each gas molecule. The following equation shows the relationship that exists between the kinetic energy and the velocity of a gas:

$$\text{K.E.} = 1/2 (mv^2)$$

where:

**K.E.** = kinetic energy of a gas molecule in joules  
**m** = mass of the gas molecule in kilograms  
**v** = velocity of the gas molecule in meters/second

You may wish to give the students some experience with this equation.

As the average kinetic energy increases, there will be a corresponding increase in the force exerted by the gas molecules as they collide with the walls of the container. This increase in the average force exerted on the walls of the container results in an increase in the measured gas pressure. If we expressed the gas temperature in terms of the Kelvin scale, we would find that (at constant volume) there will exist a direct, linear relationship between gas temperature and gas pressure.

The Kelvin temperature scale will be defined in a later paragraph.

An example of this relationship which you may have observed occurs when a car is driven for several miles on a hot day. Because of the temperature of the road and the friction between the tires and the road, the tires get warm, which causes the pressure in the tires to increase. This is why you are told to check the tire pressure before you start to drive, rather than after you have driven for a while.

The following relatively simple device (see Figure 1 on page 31) can be used to aid our understanding of the kinetic theory and to allow us to experimentally determine the relationship between the temperature and the pressure of a gas held at a constant volume. A given weight of some gas (having an initial temperature equal to  $T_1$  and an initial pressure equal to  $P_1$ ) is placed into a constant volume cylinder.

If the gas in the cylinder is now heated to a new temperature ( $T_2$ ), the kinetic energy of the gas molecules will increase, resulting in an increase in the gas pressure. The net result is an increase in gas pressure resulting from an increase in gas temperature (see Figure 2 on page 31).

The nature of the temperature/pressure relationship is such that a given incremental change in temperature will produce a corresponding incremental change in pressure. We will see that the actual curve formed by our plotted experimental data will be linear.

The concept of linear data and non-linear data should be discussed if it has not already been covered.

The following equation shows the relationship that exists between the temperature and the pressure of a gas:

$$P = k T$$

where

$P$  = gas pressure in atmospheres

$T$  = gas temperature in degrees Kelvin

$k$  = a constant that takes into account the weight and the volume of the gas

When experimenters were first investigating the relationship between the pressure and the temperature of a gas held at a constant volume, they were surprised to find that their results indicated that the gas pressure would go to zero if they could reduce the temperature to  $-273$  C. Of course, in reality the gas temperature could never be reduced to  $-273$  C, because the gas would first change to a liquid and then to a solid before that temperature could be reached. But their findings led them to wonder if there was a lower limit to the absolute value

Gas pressure =  $P_1$   
Gas volume =  $V_1$   
Gas temperature =  $T_1$

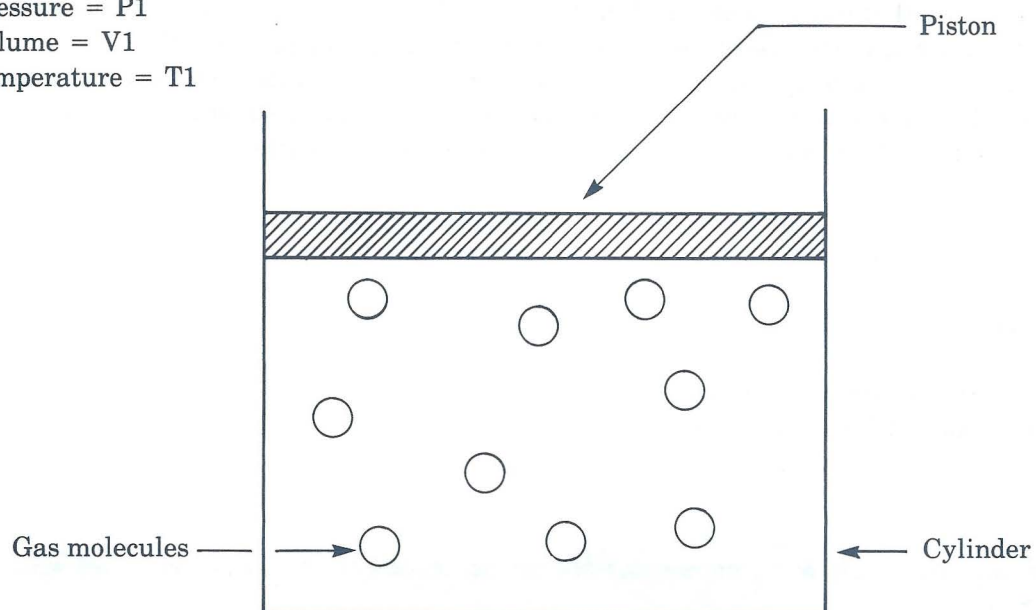

**Figure 1. Initial conditions on experimental device.**

Gas pressure =  $P_2$   
Gas volume =  $V_1$   
Gas temperature =  $T_2$

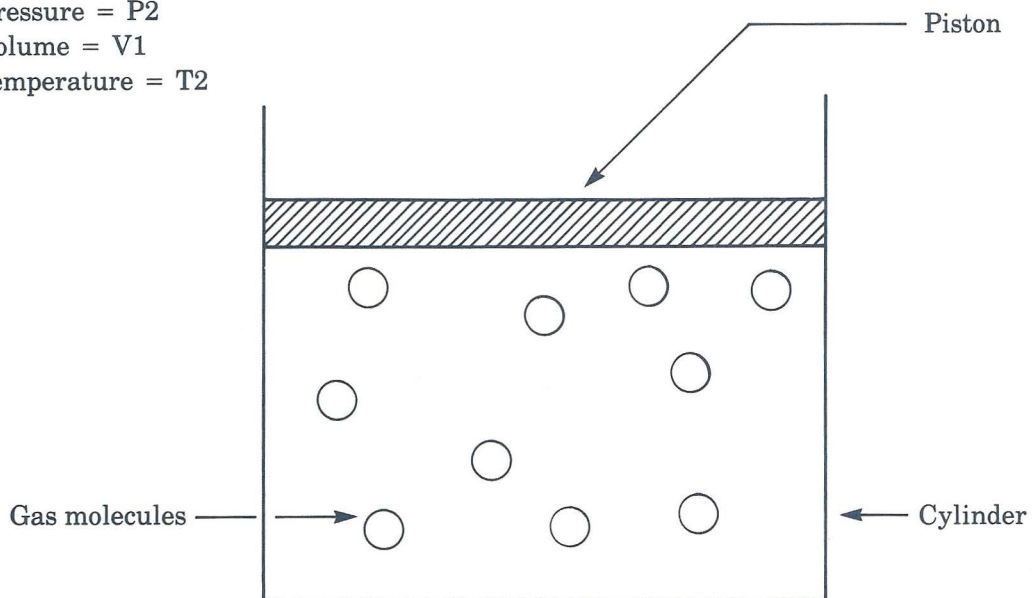

**Figure 2. Effect of increased temperature.**



of temperature that might be obtained. If there was, this temperature could then be defined as absolute zero, and the temperature at absolute zero could be set equal to  $-273\text{ C}$ . Subsequently, a new temperature scale was defined (the Kelvin scale) based upon this concept of an absolute zero temperature. One degree on the Celsius scale is equal to one Kelvin on the absolute scale and the two scales are related by the following equation:

$$T = C + 273$$

where

**T** = the Kelvin temperature

**C** = the Celsius temperature

You may wish to show (perhaps with a thermometer) how the two scales compare with each other.

## Kinetic Theory Summary Quiz

1. The kinetic theory was developed to describe the MOTION of particles.
2. The KINETIC energy of a gas molecule is related to the temperature of the gas.
3. If the temperature of a gas is increased, the kinetic energy of the gas will INCREASE.
4. If the kinetic energy of a gas decreases, the pressure exerted by the gas on the container walls will DECREASE.
5. If you released a helium-filled balloon, you would expect the balloon to DECREASE in diameter as it rose into cooler air.
6. Zero degrees on the Celsius scale is equal to 273 degrees on the Kelvin scale.

## Kinetic Theory Experimental Procedure

Before beginning the Kinetic Theory Experimental Procedure, follow the loading instructions and make at least five copies of the Kinetic Theory Data Worksheet.\*

In this experiment, you will determine the relationship between temperature and pressure of an ideal gas held at constant volume. At the beginning of the experiment, read the instructions and press **(ENTER)** to continue until you see the Part 1 experimental apparatus.

The first step in the experiment is to introduce a known quantity of gas into a cylinder. When you get to Part 1, the screen will contain a cylinder with an input port and a relief port. The input port allows gas to enter the cylinder when you wish to increase the quantity of gas, and the relief port releases gas from the cylinder when you wish to reduce the quantity. Use the **(↑)** and **(↓)** keys to introduce gas into the cylinder. You may add no less than one and no more than 19 moles of gas.

After you introduce the desired amount of gas into the cylinder, press **(ENTER)** to continue until you see the experimental apparatus for Part 2 of the procedure. As you can see, the cylinder is above a flame, which can be raised or lowered to increase or decrease the temperature. The thermometer next to the cylinder measures the temperature of the gas.

The gas temperature will initially be equal to 400 degrees Kelvin, and you will be able to increase or decrease the temperature using the **(↑)** and **(↓)** keys. There is a direct relationship between the temperature (**T**) and the pressure (**P**) of the gas: as the temperature decreases, the pressure will decrease. Also, larger quantities of gas produce larger increments in pressure for a given change in temperature.

You will plot the pressure of the gas as a function of the temperature of the gas. To do this, increase and decrease the temperature using the **(↑)** and **(↓)** keys, and press the **(S)** key after each change in temperature to store each set of data.

When you have stored all eleven sets of data, press **(ENTER)** to see the Data Table. Record this data on your Data Worksheet. Since the pressure will be a function of the quantity of gas that you placed in the cylinder, you will need to scale the y axis before you graph this data on your worksheet. See page 36 for the appropriate scaling factors for each quantity of gas, and page 35 for a Sample Data Worksheet that has been prepared for a quantity of gas equal to 10 moles.

When you have finished plotting your data on the Data Worksheet, connect the points to form a smooth curve, and then press **(ENTER)** to see the computer's graph of the eleven data points. Your plotted data should look comparable to what is plotted on the video display.

Using a new Data Worksheet, repeat this procedure for several other quantities of gas.

\* If you have not yet reviewed the section headed "HOW TO USE THE TRS-80 CHEMISTRY LAB, VOLUME I," you should do so at this time.



# Kinetic Theory Sample Data Worksheet

Gas Quantity 10 Moles

Data Set #	Gas Temp.	Gas Pressure	Data Set #	Gas Temp.	Gas Pressure
1	400	32.80	6	350	28.70
2	390	31.98	7	340	27.88
3	380	31.16	8	330	27.06
4	370	30.34	9	320	26.24
5	360	29.52	10	310	25.42
			11	300	24.60

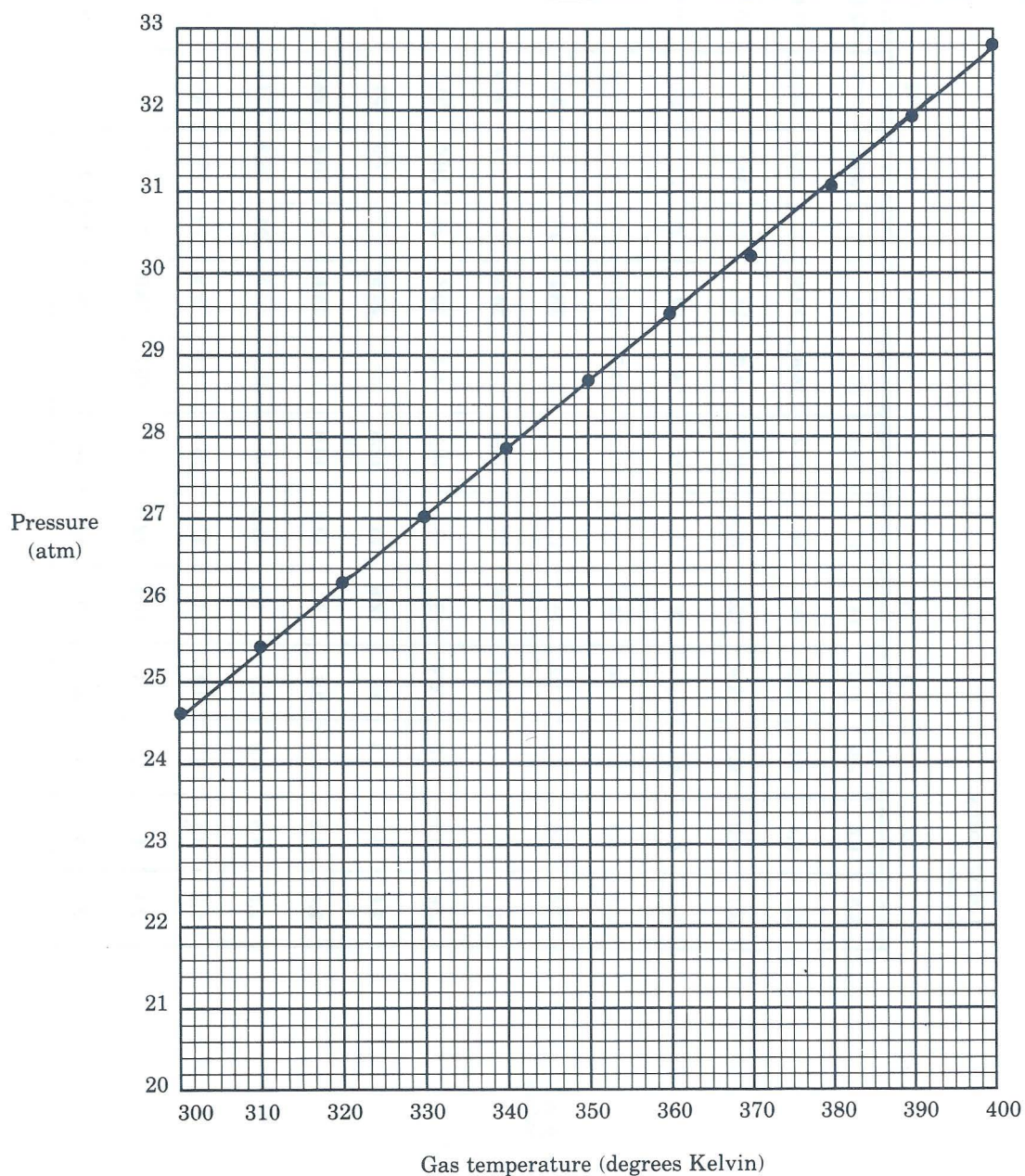

## Kinetic Theory

### Y-axis values as a function of gas quantity.

Gas Quantity in moles	1	2	3	4	5	6	7	8	9	10	11	12	13	14	15	16	17	18	19
3.3	6.6	9.9	13.2	16.5	19.8	23.1	26.4	29.7	33	36.3	39.6	42.9	46.2	49.5	52.8	56.1	59.4	62.7	
3.2	6.4	9.6	12.8	16	19.2	22.4	25.6	28.8	32	35.2	38.4	41.6	44.8	48	51.2	54.4	57.6	60.8	
3.1	6.2	9.3	12.4	15.5	18.6	21.7	24.8	27.9	31	34.1	37.2	40.3	43.4	46.5	49.6	52.7	55.8	58.9	
3	6	9	12	15	18	21	24	27	30	33	36	39	42	45	48	51	54	57	
2.9	5.8	8.7	11.6	14.5	17.4	20.3	23.2	26.1	29	31.9	34.8	37.7	40.6	43.5	46.4	49.3	52.2	55.1	
2.8	5.6	8.4	11.2	14	16.8	19.6	22.4	25.2	28	30.8	33.6	36.4	39.2	42	44.8	47.6	50.4	53.2	
2.7	5.4	8.1	10.8	13.5	16.2	18.9	21.6	24.3	27	29.7	32.4	35.1	37.8	40.5	43.2	45.9	48.6	51.3	
2.6	5.2	7.8	10.4	13	15.6	18.2	20.8	23.4	26	28.6	31.2	33.8	36.4	39	41.6	44.2	46.8	49.4	
2.5	5	7.5	10	12.5	15	17.5	20	22.5	25	27.5	30	32.5	35	37.5	40	42.5	45	47.5	
2.4	4.8	7.2	9.6	12	14.4	16.8	19.2	21.6	24	26.4	28.8	31.2	33.6	36	38.4	40.8	43.2	45.6	
2.3	4.6	6.9	9.2	11.5	13.8	16.1	18.4	20.7	23	25.3	27.6	29.9	32.2	34.5	36.8	39.1	41.4	43.7	
2.2	4.4	6.6	8.8	11	13.2	15.4	17.6	19.8	22	24.2	26.4	28.6	30.8	33	35.2	37.4	39.6	41.8	
2.1	4.2	6.3	8.4	10.5	12.6	14.7	16.8	18.9	21	23.1	25.2	27.3	29.4	31.5	33.6	35.7	37.8	39.9	
2	4	6	8	10	12	14	16	18	20	22	24	26	28	30	32	34	36	38	

y-axis  
values



# Kinetic Theory Data Worksheet

Gas Quantity \_\_\_\_\_

Data Set #	Gas Temp.	Gas Volume	Data Set #	Gas Temp.	Gas Volume
1			6		
2			7		
3			8		
4			9		
5			10		
			11		

Pressure  
(atm)

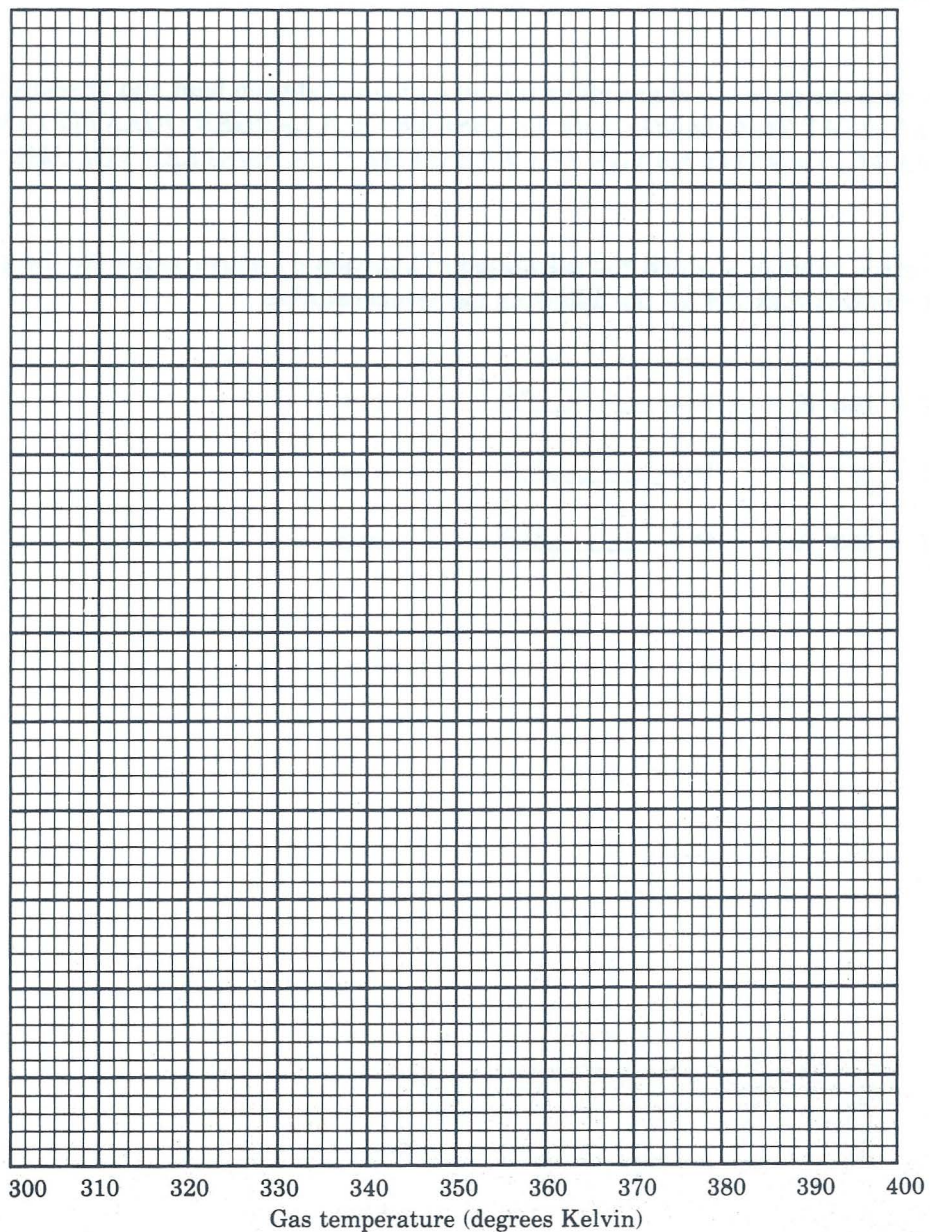



## Kinetic Theory Conclusions

Now that you have graphed the data, answer the following questions:

1. Remembering that  $P = kT$ , what is the calculated value of  $k$  for your data?

$$k = \underline{\hspace{2cm}.082\hspace{2cm}}$$

2. Does your data indicate that the relationship between temperature and pressure is a direct,

linear relationship? YES Why or why not? *THE PLOT OF THE DATA FORMS A STRAIGHT LINE WITH A NON-NEGATIVE SLOPE.*

3. How does the quantity of gas affect the relationship between heat and pressure? *IT TAKES MORE HEAT TO CHANGE THE PRESSURE OF A LARGER QUANTITY OF GAS THAN IT DOES TO CHANGE THE PRESSURE OF A SMALLER VOLUME OF GAS.*

4. Using the value of  $k$  which you calculated in question #1 above, calculate the gas pressure that you would expect for the following gas temperatures:

1.  $T = 100^\circ \text{K}$        $P = \underline{\hspace{2cm}8.2\hspace{2cm}} \text{ atm}$

2.  $T = 200^\circ \text{K}$        $P = \underline{\hspace{2cm}16.4\hspace{2cm}} \text{ atm}$

3.  $T = 500^\circ \text{K}$        $P = \underline{\hspace{2cm}41.0\hspace{2cm}} \text{ atm}$

## **Charles' Law**

**The relationship between the temperature and the volume of an ideal gas at constant pressure.**





## Charles' Law Instructional Objectives

After completing this unit, students will be able to:

1. Explain Charles' law.
2. Experimentally determine the relationship between the volume and the temperature of an ideal gas held at constant pressure.



## Charles' Law Background Information

The relationship between the temperature of a gas and the resulting volume of the gas was investigated in 1787 by the French physicist Jacques Alexandre Cesar Charles (1746-1823). Charles' law states that at a constant pressure, the volume of a fixed mass of any gas is proportional to the gas temperature. This means that the volume of a gas will decrease as temperature decreases and will increase as temperature increases, if the pressure remains constant.

You may wish to expand upon this by asking why the pressure would need to remain constant.

The kinetic theory can be used to explain why this phenomenon occurs. According to the kinetic theory, an increase in gas temperature will cause the molecules of a gas to move about more rapidly, causing the gas to exert increased pressure on the walls of its container. Since pressure is to be held at a constant value, we will see (in the experiment) that the gas will have to increase in volume. Conversely, if a gas is cooled, the molecules will move about less rapidly and the gas will decrease in volume.

The following relatively simple device (see Figure 1 on page 44) can be used to aid our understanding of Charles' law, and to allow us to experimentally determine the relationship between the volume and the temperature of a gas held at a constant pressure. The device consists of a cylinder having a movable piston for its top surface. We will assume that this piston has an external force applied to it that is equal to 1 atmosphere of pressure. A given weight of some gas (having an initial temperature equal to  $T_1$  and an initial pressure equal to  $P_1$ ) is placed into the cylinder. Since the piston is free to move up or down (either increasing or decreasing the volume of the cylinder), it will move until the gas pressure in the cylinder is equal to the external force that is being applied to the cylinder (1 atmosphere).

If the gas in the cylinder is now heated to a new temperature ( $T_2$ ), the kinetic energy of the gas molecules will increase, resulting in an increase in the gas pressure. This increase in internal pressure will cause the free-floating piston to rise to a new level (increasing the volume of the cylinder) so that the gas pressure remains at 1 atmosphere (see Figure 2 on page 44). The net result is an increase in gas volume resulting from an increase in gas temperature.

You may want to review the concept of linear momentum to help explain why the gas molecules create an increase in pressure when their velocity increases.

The nature of the temperature/volume relationship described by Charles' law is such that a given incremental change in temperature will produce a corresponding incremental change in volume. We will see that the actual curve formed by our plotted experimental data will be linear.



Gas pressure =  $P_1$   
Gas volume =  $V_1$   
Gas temperature =  $T_1$

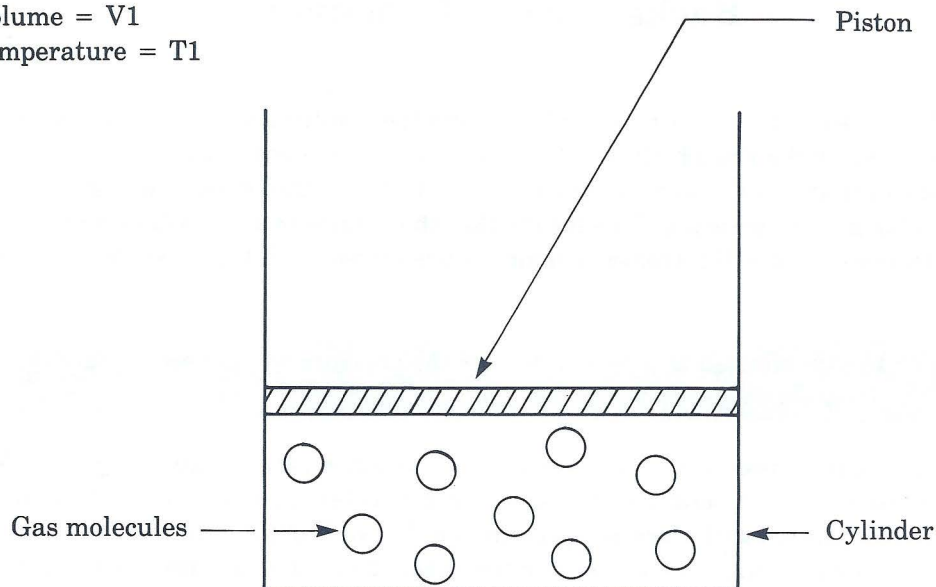

**Figure 1. Initial conditions on experimental device.**

Gas pressure =  $P_1$   
Gas volume =  $V_2$   
Gas temperature =  $T_2$

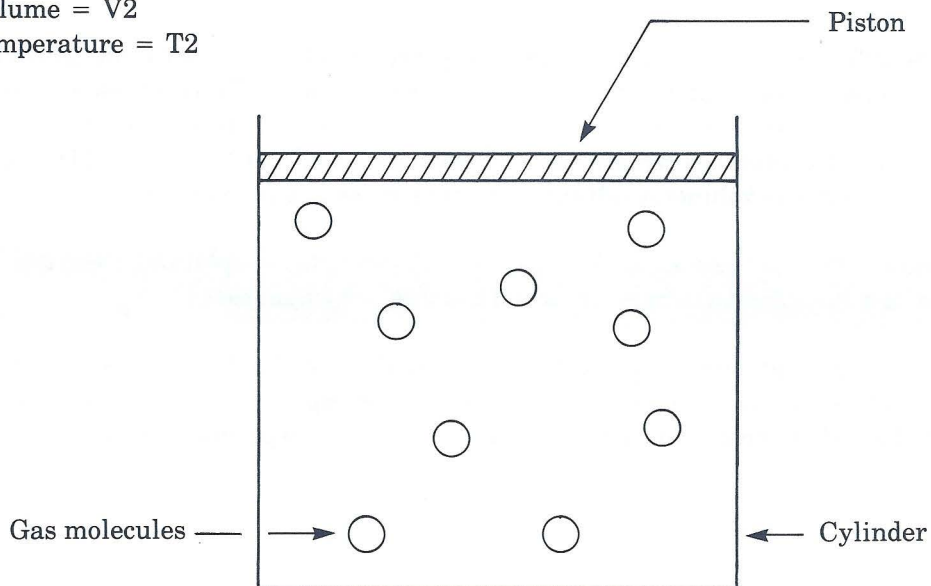

**Figure 2. Effect of increased temperature**

The operation of the experimental device can be explained by again reviewing the kinetic theory. If we increase the temperature of the gas, there will be a resultant increase in the average velocity of each gas molecule. Consequently, the gas molecules will strike the cylinder walls with increased force, causing the gas pressure to rise. Since the gas pressure was to remain constant, the piston will move, causing the volume to increase. The piston will continue to move until the gas pressure in the cylinder is equal to the externally applied force.

The following equation shows the relationship that exists between the temperature and the volume of a gas.

$$V = k'T$$

where

**T** = gas temperature in degrees Kelvin

**V** = gas volume in liters

**k'** = a constant that takes into account the mass and the pressure of the gas

You may want to give the students some experience with this equation.

## Charles' Law Summary Quiz

1. Charles' Law relates the VOLUME and the TEMPERATURE  
of a fixed weight of any gas held at a constant PRESSURE .

2. What is the equation that relates the temperature and the volume of a fixed weight of gas held at a constant pressure?

$$V = \frac{kT}{P}$$

3. If you measured the gas volume for several gas temperatures, you would find that the gas volume varies DIRECTLY / PROPORTIONALLY / LINEARLY with the gas temperature.

4. If you plotted the gas volume as a function of gas temperature, you would find that the curve was LINEAR .

## Charles' Law Experimental Procedure

Before beginning the Charles' Law Experimental Procedure, follow the loading instructions and make at least five copies of the Charles' Law Data Worksheet.\*

In this experiment, you will determine the relationship between the temperature and the volume of an ideal gas held at constant pressure. At the beginning of the experiment, read the instructions and press **(ENTER)** to continue until you see the Part 1 experimental apparatus.

The first step in the experiment is to introduce a known quantity of gas into a cylinder. When you get to Part 1, the screen will contain a cylinder with an input port and a relief port. The input port transfers gas into the cylinder when you wish to increase the quantity of gas, and the relief port transfers gas out of the cylinder when you wish to reduce the quantity. Use the **(↑)** and **(↓)** keys to introduce a quantity of gas into the cylinder. You may add no less than one and no more than 19 moles of gas.

After you introduce the desired amount of gas into the cylinder, press **(ENTER)** to continue until you see the experimental apparatus for Part 2 of the procedure. As you can see, the cylinder is above a flame, which can be raised or lowered to increase or decrease the temperature. The thermometer next to the cylinder measures the temperature of the gas.

The gas temperature will initially be equal to 400 degrees Kelvin, and you will be able to increase or decrease the temperature using the **(↑)** and **(↓)** keys. There is a direct relationship between the temperature (**T**) and the volume (**V**) of the gas: as the temperature decreases, the volume will decrease.

You will plot the volume of the gas as a function of the temperature of the gas. To do this, increase and decrease the temperature using the **(↑)** and **(↓)** keys, and press the **(S)** key after each change in temperature to store each set of data.

When you have stored all eleven sets of data, press **(ENTER)** to see the Data Table. Record this data on your Data Worksheet. Since the volume is a function of the quantity of gas that you placed in the cylinder, you will need to scale the *y* axis before you graph this data on your worksheet. See page 49 for the appropriate scaling factors for each quantity of gas, and page 48 for a Sample Data Worksheet that has been prepared for a quantity of gas equal to 10 moles.

When you have finished plotting your data on the Data Worksheet, connect the points to form a smooth curve, and then press **(ENTER)** to see the computer's graph of the eleven data points. Your plotted data should look comparable to what is plotted on the video display.

Using a new Data Worksheet, repeat this procedure for several other quantities of gas.

\*If you have not yet reviewed the section headed "HOW TO USE THE TRS-80 CHEMISTRY LAB, VOLUME I," you should do so at this time.



# Charles' Law Sample Data Worksheet

Gas Quantity 10 moles

Data Set #	Gas Temp.	Gas Volume	Data Set #	Gas Temp.	Gas Volume
1	400	328.0	6	350	287.0
2	390	319.8	7	340	278.8
3	380	311.6	8	330	270.6
4	370	303.4	9	320	262.4
5	360	295.2	10	310	254.2
			11	300	246.0

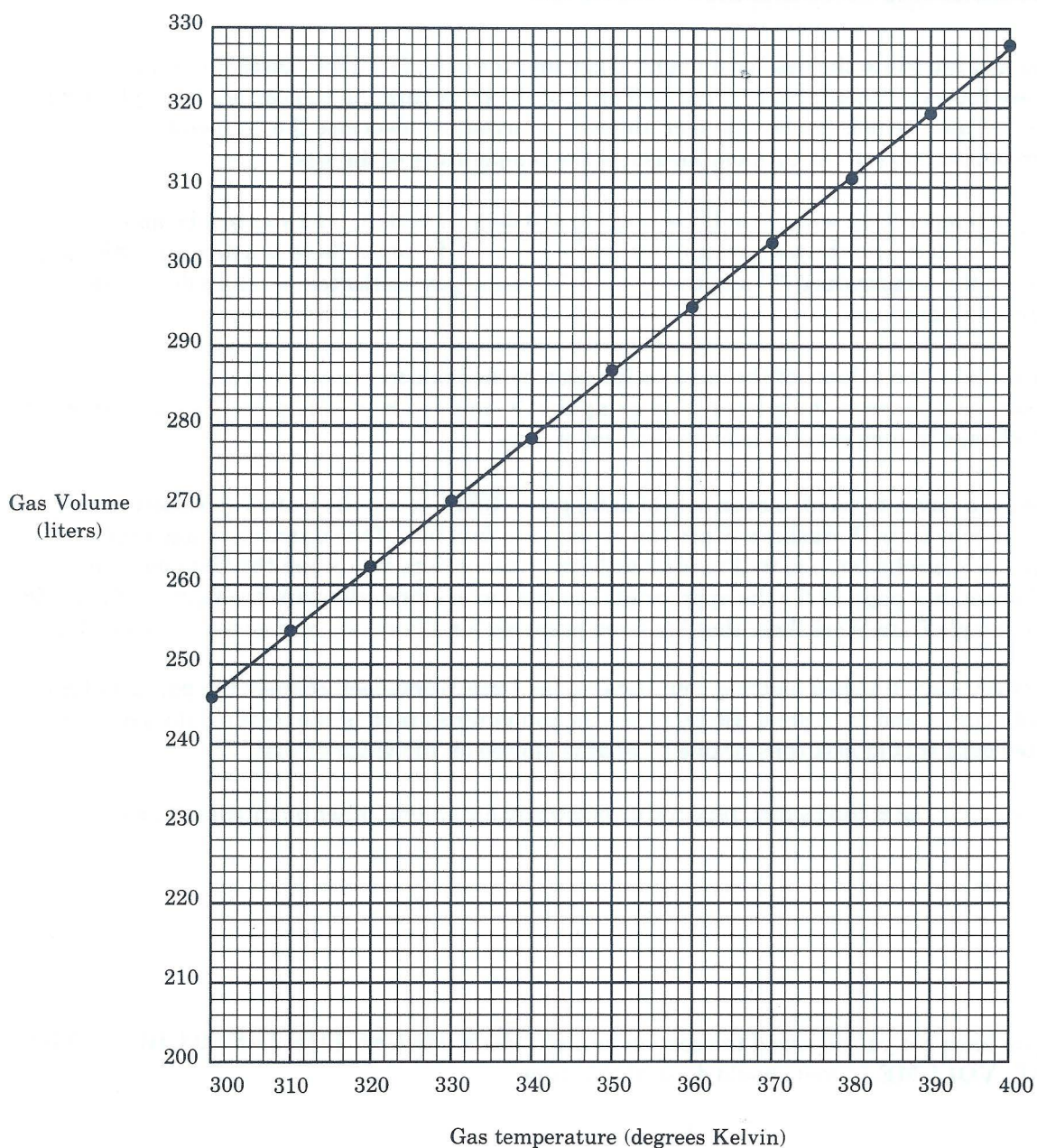

## Charles' Law

### Y-axis values as a function of gas quantity.

Gas Quantity in moles	1	2	3	4	5	6	7	8	9	10	11	12	13	14	15	16	17	18	19
33	66	132	198	264	330	396	462	528	594	660	726	792	858	924	990	1056	1122	1188	1254
32	64	128	192	256	320	384	448	512	576	640	704	768	832	896	960	1024	1088	1152	1216
31	62	124	186	248	310	372	434	496	558	620	682	744	806	868	930	992	1054	1116	1178
30	60	120	180	240	300	360	420	480	540	600	660	720	780	840	900	960	1020	1080	1140
29	58	116	174	232	290	348	406	464	522	580	638	696	754	812	870	928	986	1044	1102
28	56	112	168	224	280	336	392	448	504	560	616	672	728	784	840	896	952	1008	1064
27	54	108	162	216	270	324	378	432	486	540	594	648	702	756	810	864	918	972	1026
26	52	104	156	208	260	312	364	416	468	520	572	624	676	728	780	832	884	936	988
25	50	100	150	200	250	300	350	400	450	500	550	600	650	700	750	800	850	900	950
24	48	96	144	192	240	288	336	384	432	480	528	576	624	672	720	768	816	864	912
23	46	92	138	184	230	276	322	368	414	460	506	552	598	644	690	736	782	828	874
22	44	88	132	176	220	264	308	352	396	440	484	528	572	616	660	704	748	792	836
21	42	84	126	168	210	252	294	336	378	420	462	504	546	588	630	672	714	756	798
20	40	80	120	160	200	240	280	320	360	400	440	480	520	560	600	640	680	720	760

y-axis  
values



# Charles' Law Data Worksheet

Gas Quantity \_\_\_\_\_

Data Set #	Gas Temp.	Gas Volume	Data Set #	Gas Temp.	Gas Volume
1			6		
2			7		
3			8		
4			9		
5			10		
			11		

Gas volume  
(liters)

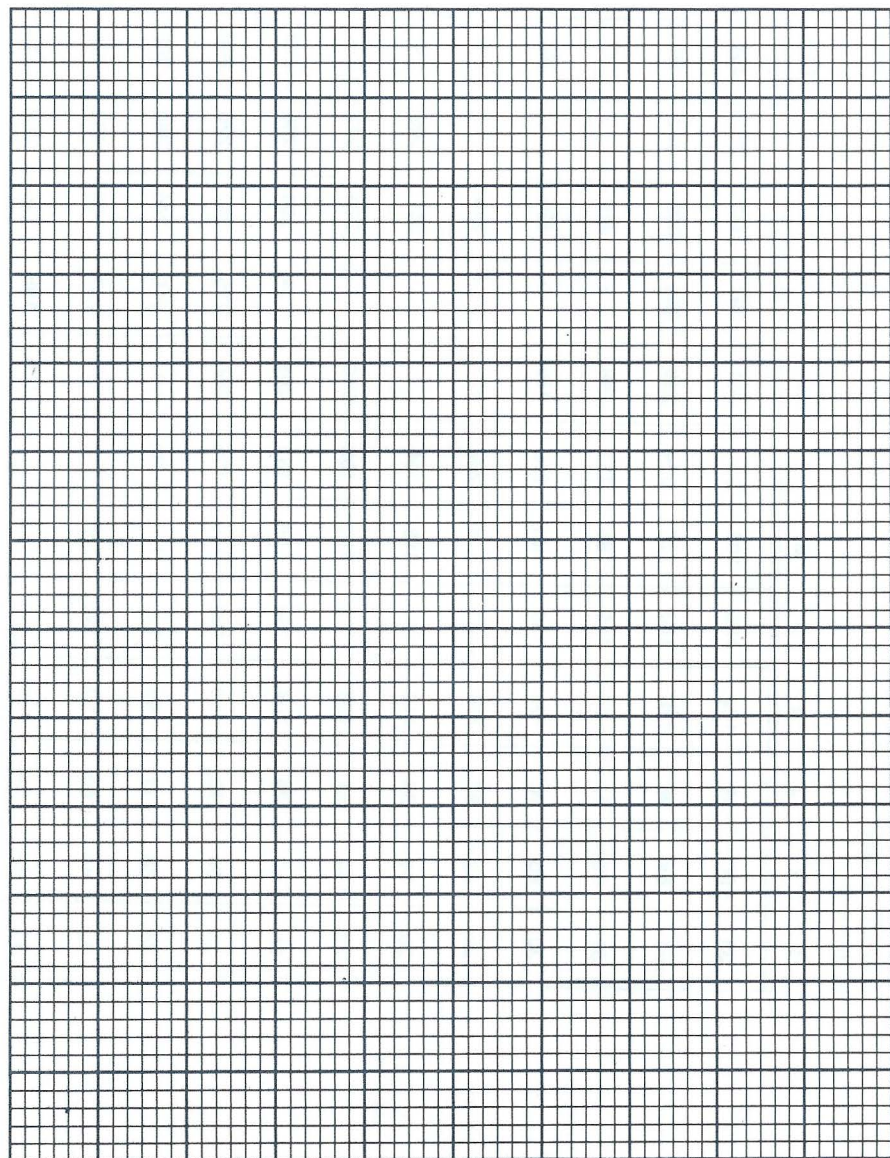

300 310 320 330 340 350 360 370 380 390 400  
Gas temperature (degrees Kelvin)

## Charles' Law Conclusions

Now that you have graphed the data, answer the following questions:

1. Remembering that  $V = k'T$ , what is the calculated value of  $k'$  for your data?

$$k' = \underline{\hspace{2cm}.82\hspace{2cm}}$$

2. Does your data indicate that the relationship between temperature and volume is a direct,

linear relationship? YES Why or why not? *GRAPH OF DATA IS A STRAIGHT LINE WITH A NON-NEGATIVE SLOPE.*

3. Using the value of  $k'$  which you calculated in question #1 above, calculate the gas volume that you would expect for the following gas temperatures:

1.  $T = 100^\circ \text{K}$      $V = \underline{\hspace{2cm}.82\hspace{2cm}}$  liters

2.  $T = 200^\circ \text{K}$      $V = \underline{\hspace{2cm}1.64\hspace{2cm}}$  liters

3.  $T = 500^\circ \text{K}$      $V = \underline{\hspace{2cm}4.10\hspace{2cm}}$  liters





## **Boyle's Law**

**The relationship between the pressure and the volume of an ideal gas at constant temperature.**



## **Boyle's Law Instructional Objectives**

After completing this unit, students will be able to:

1. Explain Boyle's Law.
2. Experimentally determine the relationship between the volume and the pressure of an ideal gas held at constant temperature.





## Boyle's Law Background Information

The relationship between the pressure of a gas and the resulting volume of the gas was investigated by the English chemist Robert Boyle (1627-1691). Boyle's law states that at constant temperature, the volume of a fixed weight of any gas is inversely proportional to the gas pressure. This means that the volume of a gas will decrease as the pressure increases, and will increase as the pressure decreases.

You may wish to explain to the students what is meant by "inversely proportional" and possibly use an example (such as using a bicycle pump) to illustrate this phenomenon.

The kinetic theory can be used to explain why this phenomenon occurs. According to the kinetic theory, if we were to increase the quantity of a gas contained in a given volume, we would find that the number of collisions between gas molecules and the walls of the container would increase, causing a corresponding increase in the gas pressure. Conversely, if the quantity of a gas contained in a given volume were decreased, we would find that the number of collisions between gas molecules would decrease, causing a decrease in gas pressure.

The following relatively simple device (see Figure 1 on page 58) can be used to aid our understanding of Boyle's law, and to allow us to experimentally determine the mathematical relationship between the volume and the pressure of a gas held at a constant temperature. The device consists of a cylinder having a movable piston for its top surface. We will assume that this piston initially has a force applied to it that is equal to 1 atmosphere of pressure. A given weight of some gas (having an initial temperature equal to  $T_1$  and an initial pressure equal to  $P_1$ ) is placed into the cylinder. Since the piston is free to move up or down (increasing or decreasing the volume of the cylinder), it will move until the gas pressure ( $P_1$ ) is equal to 1 atmosphere.

If we now increase the external force applied to the piston until it is equal to 2 atmospheres, we will find that the volume of the cylinder will decrease until the gas pressure in the cylinder is also equal to 2 atmospheres. The resulting movement of the piston (see Figure 2 on page 58) will reduce the volume of the cylinder until the gas occupies 1/2 of its original volume ( $V_2 = .5 \cdot V_1$ ).

You may wish to explain why we assume that the temperature will remain constant and how this is accomplished.

The nature of the pressure/volume relationship described by Boyle's law is such that it takes ever-increasing increments of pressure to reduce the volume by some fixed amount. We will see that the actual curve formed by our plotted experimental data will be hyperbolic.

Gas pressure =  $P_1$   
Gas volume =  $V_1$   
Gas temperature =  $T_1$

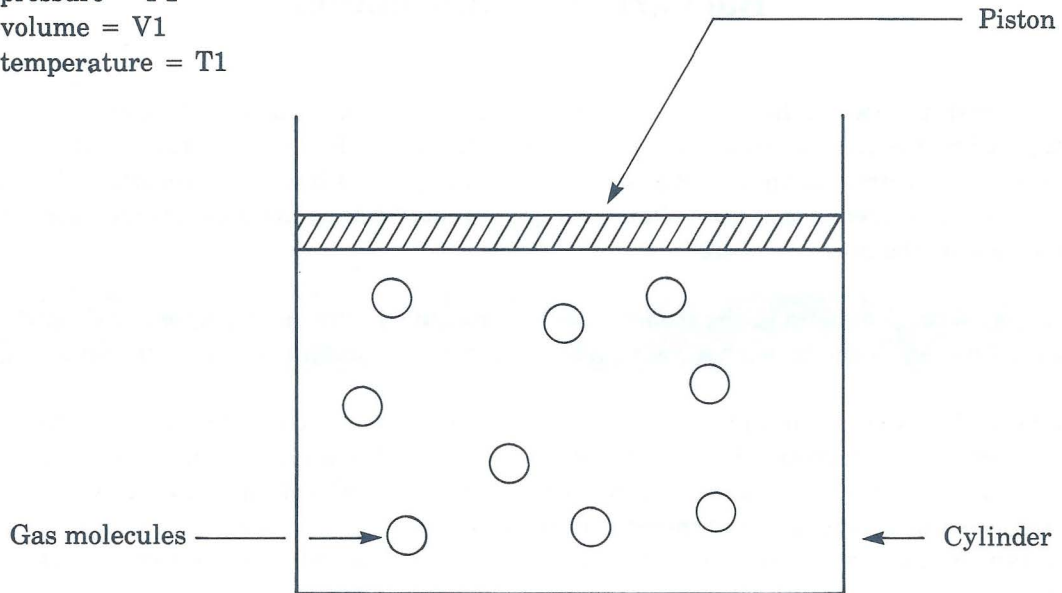

**Figure 1. Initial conditions on experimental device.**

Gas pressure =  $P_2$   
Gas volume =  $V_2$   
Gas temperature =  $T_1$

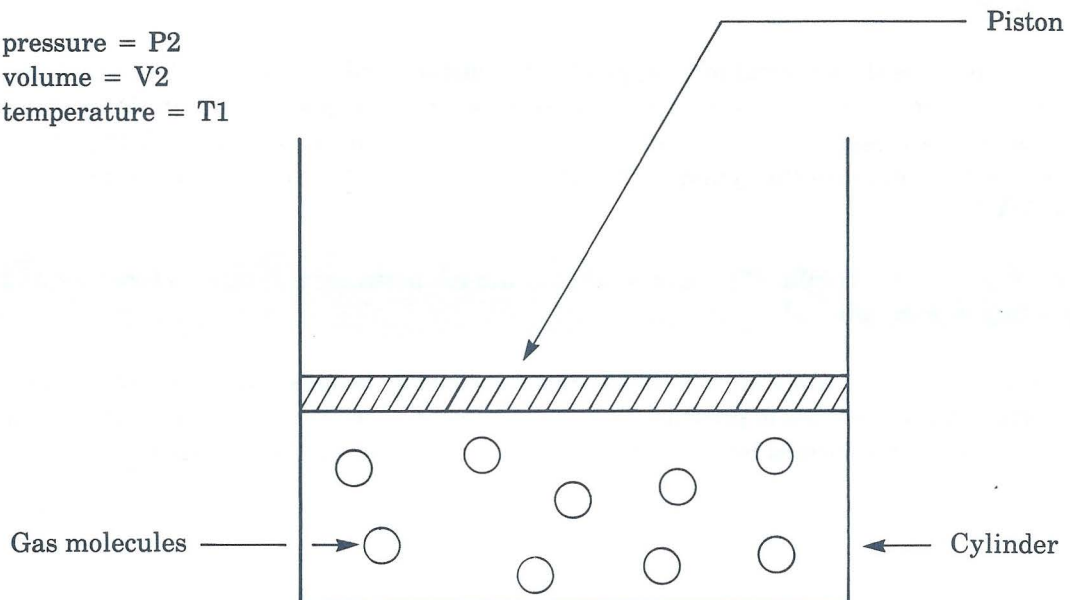

**Figure 2. Effect of increased pressure.**

The operation of the experimental device can be explained by again reviewing the kinetic theory. If we increase the external force applied to the piston, we will cause movement of the piston in such a direction as to reduce the volume of the cylinder. If the volume of the cylinder is reduced, we effectively increase the number of gas molecules per unit of volume. On the average, the gas molecules will now collide with the cylinder walls twice as often, causing an increase in gas pressure. The movement of the piston will cause the gas pressure in the cylinder to increase until this pressure is equal to the externally applied force.

The following equation shows the relationship that exists between the pressure and the volume of a gas:

$$P = k''/V$$

where

**P** = gas pressure in atmospheres

**V** = gas volume in liters

**k''** = a constant that takes into account the mass and the temperature of the gas

You may want to give the students some experience with this equation.



## Boyle's Law Summary Quiz

1. Boyle's law relates the PRESSURE and the VOLUME of a fixed mass of any ideal gas held at a constant TEMPERATURE.
2. What is the equation that relates the pressure and the volume of a fixed mass of gas held at a constant temperature?  $k' = PV$ .
3. If you measured the gas pressure for several gas volumes, you would find that the gas pressure varies INVERSELY with the gas volume.
4. If you plotted the gas volume as a function of gas pressure, you would find that the curve was HYPERBOLIC.

## Boyle's Law Experimental Procedure

Before beginning the Boyle's Law Experimental Procedure, follow the loading instructions and make at least five copies of the Boyle's Law Data Worksheet.\*

In this experiment, you will determine the relationship between the pressure and the volume of an ideal gas held at constant temperature. At the beginning of the experiment, read the instructions and press **(ENTER)** to continue until you see the Part 1 experimental apparatus.

The first step in the experiment is to introduce a known quantity of gas into a cylinder. When you get to Part 1, the screen will contain a cylinder with an input port and a relief port. The input port transfers gas into the cylinder when you wish to increase the quantity of gas, and the relief port transfers gas out of the cylinder when you wish to reduce the quantity. Use the **(↑)** and **(↓)** keys to introduce a quantity of gas into the cylinder. You may add no less than one and no more than 19 moles of gas.

After you introduce the desired amount of gas into the cylinder, press **(ENTER)** to continue until you see the experimental apparatus for Part 2 of the procedure. The gas pressure will initially be equal to 1 atmosphere, and you will be able to increase or decrease the pressure of the gas by controlling the piston on the experimental apparatus with the **(↑)** and **(↓)** keys. There is an inverse relationship between the pressure (**P**) and the volume (**V**) of the gas: as the pressure increases, the volume will decrease. Also, larger quantities of gas produce larger increments of change in volume.

You will plot the volume of the gas as a function of the pressure of the gas. To do this, increase and decrease the pressure using the **(↑)** and **(↓)** keys, and press the **(S)** key after each change in pressure to store each set of data.

When you have stored all ten sets of data, press **(ENTER)** to see the Data Table. Record the displayed data on your Data Worksheet. Since the volume is a function of the quantity of gas that you placed in the cylinder, you will need to scale the *y* axis before you graph this data on your worksheet. See page 63 for the appropriate scaling factors for each quantity of gas, and page 62 for a Sample Data Worksheet that has been prepared for a quantity of gas equal to 10 moles.

When you have finished plotting your data on the Data Worksheet, connect the points to form a smooth curve, and then press **(ENTER)** to see the computer's graph of the eleven data points. Your plotted data should look comparable to what is plotted on the video display.

Using a new Data Worksheet, repeat this procedure for several other quantities of gas.

\*If you have not yet reviewed the section headed "HOW TO USE THE TRS-80 CHEMISTRY LAB, VOLUME I," you should do so at this time.

# Boyle's Law Sample Data Worksheet

Gas Quantity 10 moles

Data Set #	Gas Pressure	Gas Volume	Data Set #	Gas Pressure	Gas Volume
1	1	328.0	6	6	54.7
2	2	164.0	7	7	46.9
3	3	109.3	8	8	41.0
4	4	82.0	9	9	36.4
5	5	65.6	10	10	32.8

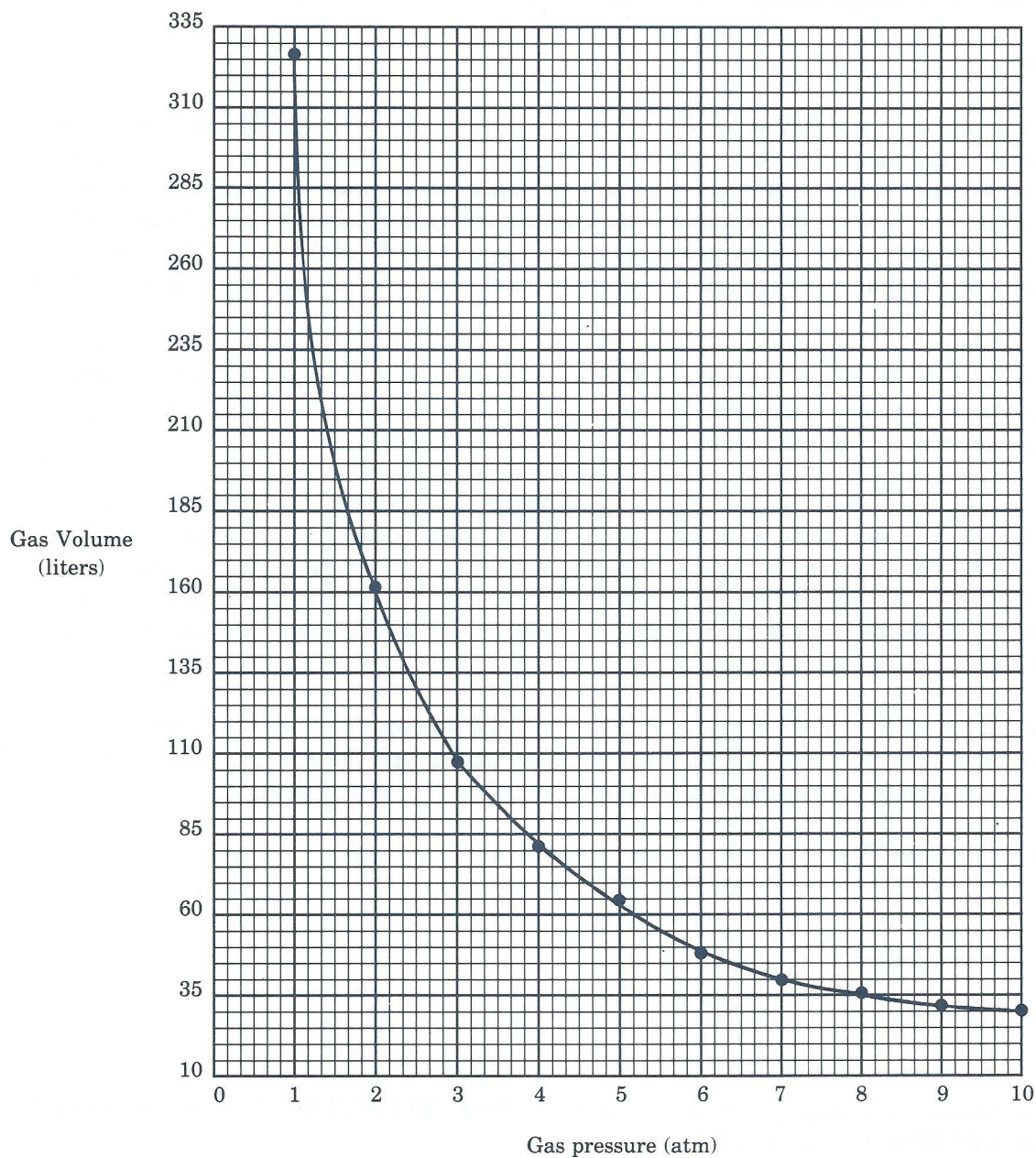



## Boyle's Law

### Y-axis values as a function of gas quantity.

Gas Quantity in moles	1	2	3	4	5	6	7	8	9	10	11	12	13	14	15	16	17	18	19
33.5	67	100.5	134	167.5	201	234.5	268	301.5	335	368.5	402	435.5	469	502.5	536	569.5	603	636.5	
31	62	93	124	155	186	217	248	279	310	341	372	403	434	465	496	527	558	589	
28.5	57	85.5	114	142.5	171	199.5	228	256.5	285	313.5	342	370.5	399	427.5	456	484.5	513	541.5	
26	52	78	104	130	156	182	208	234	260	286	312	338	364	390	416	442	468	494	
23.5	47	70.5	94	117.5	141	164.5	188	211.5	235	258.5	282	305.5	329	352.5	376	399.5	423	446.5	
21	42	63	84	105	126	147	168	189	210	231	252	273	294	315	336	357	378	399	
18.5	37	55.5	74	92.5	111	129.5	148	166.5	185	203.5	222	240.5	259	277.5	296	314.5	333	351.5	
16	32	48	64	80	96	112	128	144	160	176	192	208	224	240	256	272	288	304	
13.5	27	40.5	54	67.5	81	94.5	108	121.5	135	148.5	162	175.5	189	202.5	216	229.5	243	256.5	
11	22	33	44	55	66	77	88	99	110	121	132	143	154	165	176	187	198	209	
8.5	17	25.5	34	42.5	51	59.5	68	76.5	85	93.5	102	110.5	119	127.5	136	144.5	153	161.5	
6	12	18	24	30	36	42	48	54	60	66	72	78	84	90	96	102	108	114	
3.5	7	10.5	14	17.5	21	24.5	28	31.5	35	38.5	42	45.5	49	52.5	56	59.5	63	66.5	
1	2	3	4	5	6	7	8	9	10	11	12	13	14	15	16	17	18	19	

Y-axis  
values



# Boyle's Law Data Worksheet

Gas Quantity \_\_\_\_\_

Data Set #	Gas Pressure	Gas Volume	Data Set #	Gas Pressure	Gas Volume
1			6		
2			7		
3			8		
4			9		
5			10		

Gas volume  
(liters)

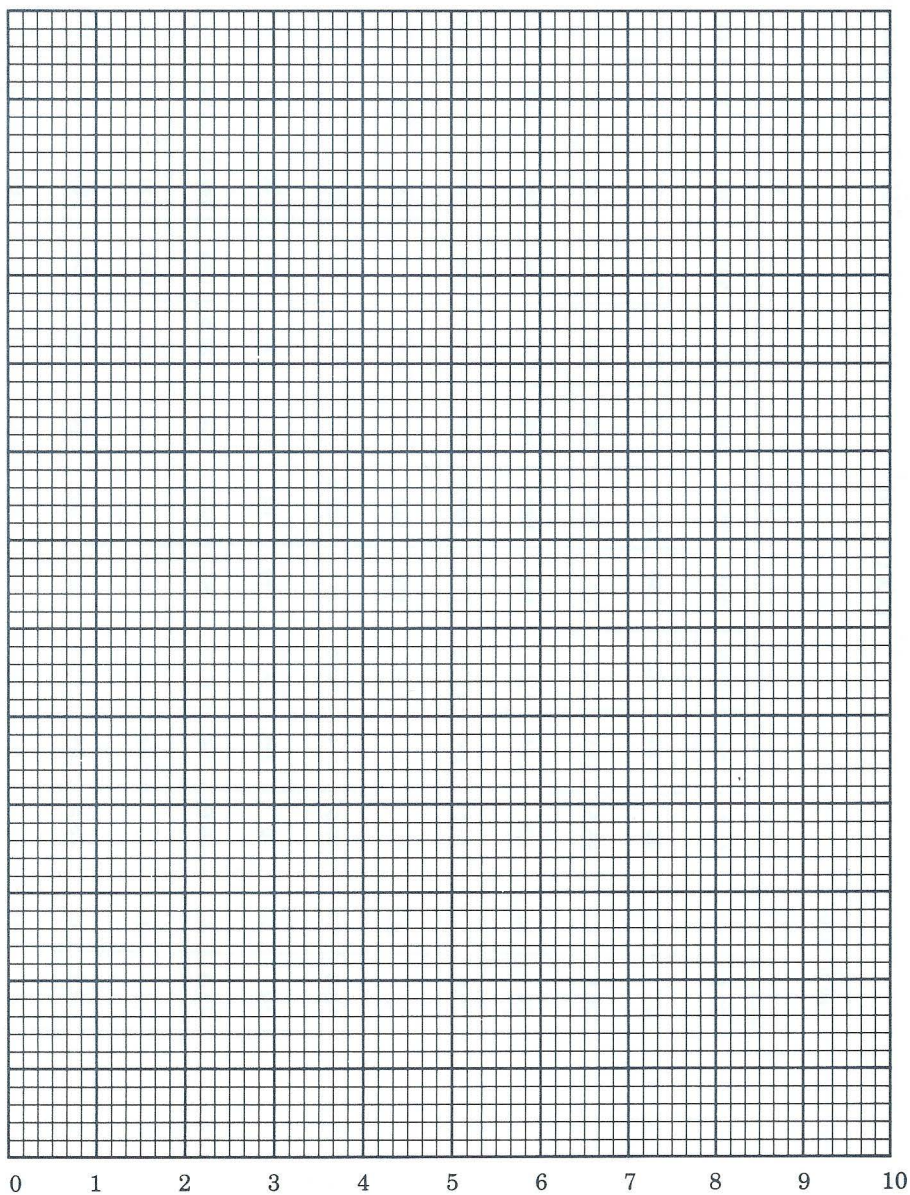

Gas pressure (atm)

## Boyle's Law Conclusions

Now that you have graphed the data, answer the following questions:

1. Remembering that  $P = k''/V$ , what is the calculated value of  $k''$  for your data?

$$k'' = \frac{328.0}{\quad}$$

2. Your data indicates that the relationship between pressure and volume is

HYPERBOLIC.

3. Using the value of  $k''$  which you calculated in question #1 above, calculate the gas volume that you would expect for the following gas pressures:

1.  $P = 40$  atmospheres       $V = \frac{8.20}{\quad}$  liters

2.  $P = 100$  atmospheres       $V = \frac{3.28}{\quad}$  liters

3.  $P = 5.2$  atmospheres       $V = \frac{63.08}{\quad}$  liters



## **Conductivity**

**Determination of the conductivity of ionic solutions.**





## Conductivity Instructional Objectives

After completing this unit, students will be able to:

1. Define "conductivity."
2. Experimentally determine the conductivity of several solutions.
3. Discuss the relationship between resistance and conductivity.



## Conductivity Background Information

*Conductivity* can be defined as a measure of the capacity for movement of electric current through a substance. Substances whose aqueous solutions are conductive are called electrolytes; substances whose aqueous solutions are non-conductive are called nonelectrolytes.

You may wish to illustrate how compounds (electrolytes) that form conductive solutions break into positive and negative components.

In order to understand conductivity, it will be necessary to first define *electric current* and to understand the conditions that must exist before an electric current can flow through a solution.

We know that when an ionic solid is dissolved in water, the substance dissociates into positive and negative components called “cations” (positively charged particles) and “anions” (negatively charged particles). If two metal electrodes are placed into an aqueous solution and a voltage is applied across the electrodes, there will be established in the solution a voltage gradient which can produce a net force on a charged particle. This electromotive force (EMF) will cause cations to be attracted to the negative electrode, and anions to be attracted to the positive electrode. This movement of cations and anions is called “electric current.”

Make sure that the students understand that the positive particles are attracted to the negative electrode and that the negative particles are attracted to the positive electrode.

Increasing the magnitude of the voltage that is applied across the electrodes will cause the cations and anions to move faster, thus increasing the magnitude of the electric current. Increasing the total number of cations and anions in the solution also causes an increase in the electric current. Therefore, we can conclude that the magnitude of electric current flowing through a solution is directly related to both the total number of cations and anions in the solution, and the magnitude of the electromotive force (voltage) applied across the solution. Using this information, we can build a relatively simple apparatus (see Figure 1 on page 72) which can be used to give a relative indication of solution conductivity.

The apparatus has two electrodes, connected to a variable voltage source, which are placed into the solution whose conductivity is to be measured. By measuring the voltage that is applied across the two electrodes and the current that flows through the solution, the conductivity of the solution can be calculated. The following equation shows the relationship that exists between the conductivity of a solution, the voltage applied, and the current produced.

$$C = I/V$$

where

**C** = conductivity (mhos)

**I** = current (amperes)

**V** = voltage (volts)

You may wish to give the students some experience with this equation.



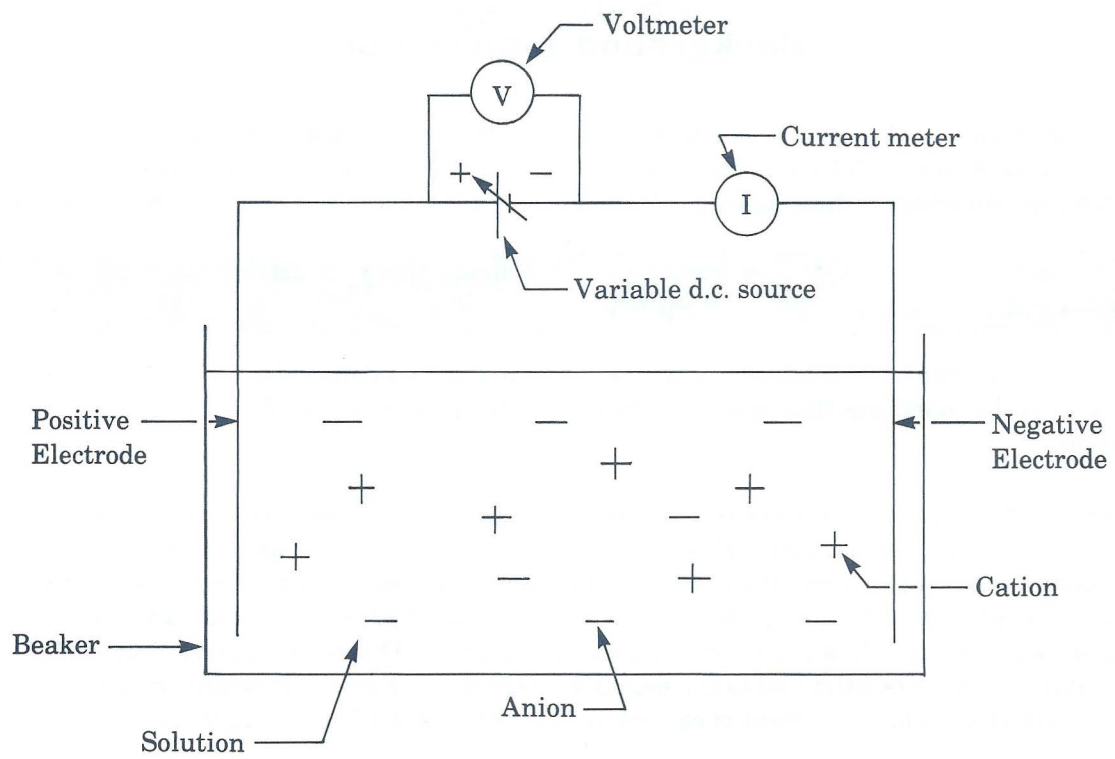

**Figure 1. Experimental device.**

If you placed distilled water in the apparatus, you would see that very little current would flow, even when large voltages were applied. The conductivity of distilled water is very low because the process of distillation removes almost all of the dissolved ionic matter; consequently, there are no cations and anions present to move through the solution.

Adding sugar to distilled water will have little effect on the magnitude of conductivity, since sugar does not dissociate into cations and anions. However, adding salt to the solution will cause a large current to flow (and a large increase in conductivity) since salt readily dissociates into cations and anions. Our experimental results would indicate that salt water has a large value of conductivity while sugar water and pure water both have small values of conductivity.

You may want to have the students review the relative placement of solutions if they were ranked according to their value of conductivity.

Resistance is a common term used in reference to electrical circuits. Resistance is a measure of the capacity of a substance to resist the flow of current. The relationship between the resistance of a solution, the voltage applied, and the current produced can be expressed by the following equation:

$$R = 1/C = V/I$$

where

**R** = resistance (ohms)

**C** = conductivity (mhos)

**I** = current (amperes)

**V** = voltage (volts)

Be sure the students understand that resistance is just the inverse of conductivity.

## Conductivity Summary Quiz

1. Conductivity is a measure of the number of free CATIONS AND ANIONS  
in a solution.

2. If we apply a voltage across a solution and measure the current flowing through the solution, then we can get a relative measure of conductivity from the equation

$$C = \frac{I}{V}$$

3. Ranking the three solutions that we discussed in terms of conductivity (lowest to highest), we would have:

1. DISTILLED WATER

2. SUGAR WATER

3. SALT WATER

## Conductivity Experimental Procedure

Before beginning the Conductivity Experimental Procedure, follow the loading instructions and make at least five copies of the Conductivity Data Worksheet.\*

In this experiment, you will be presented with a list of five solutions and will determine the conductivity of each solution. At the beginning of the experiment, choose the solution you want to work with first and enter the digit associated with that solution.

When the experimental apparatus appears, the voltage (**V**) that is being applied across the electrodes and the current (**I**) flowing through the solution will be displayed on the screen. Note that when there is no voltage ( $V = 0$ ) applied across the electrodes there will be no current ( $I = 0$ ) flowing through the solution.

You will plot the current that flows through a solution for a given voltage applied across that solution. To do this, increase and decrease the voltage using the  $\uparrow$  and  $\downarrow$  keys, and press the **S** key after each change in voltage to store each set of data. Notice that there is a direct relationship between the voltage that is applied and the current that flows: as the voltage increases, the rate of ionic movement also increases.

After collecting ten sets of data, press **ENTER** to see the Data Table. Record this data on your Data Worksheet. Since the current through the solution depends on the chemical substance you have chosen to use, you need to scale the  $y$  axis before you graph this data on your worksheet. See page 77 for the appropriate scaling factors for each solution, and page 76 for a Sample Data Worksheet that has been prepared for distilled water (substance #1).

When you have finished plotting your data on the Data Worksheet, connect the points to form a smooth curve, and then press **ENTER** to see the computer's graph of the ten data points. Your plotted data should look comparable to what is plotted on the video display.

Using a new Data Worksheet, repeat this procedure for the other four solutions.

\*If you have not yet reviewed the section headed "HOW TO USE THE TRS-80 CHEMISTRY LAB, VOLUME I," you should do so at this time.



# Conductivity Sample Data Worksheet

SOLUTION NAME: Distilled Water

Data Set #	Electrode Voltage (volts)	Solution Current (amperes)
1	10	.01
2	40	.04
3	70	.07
4	100	.1

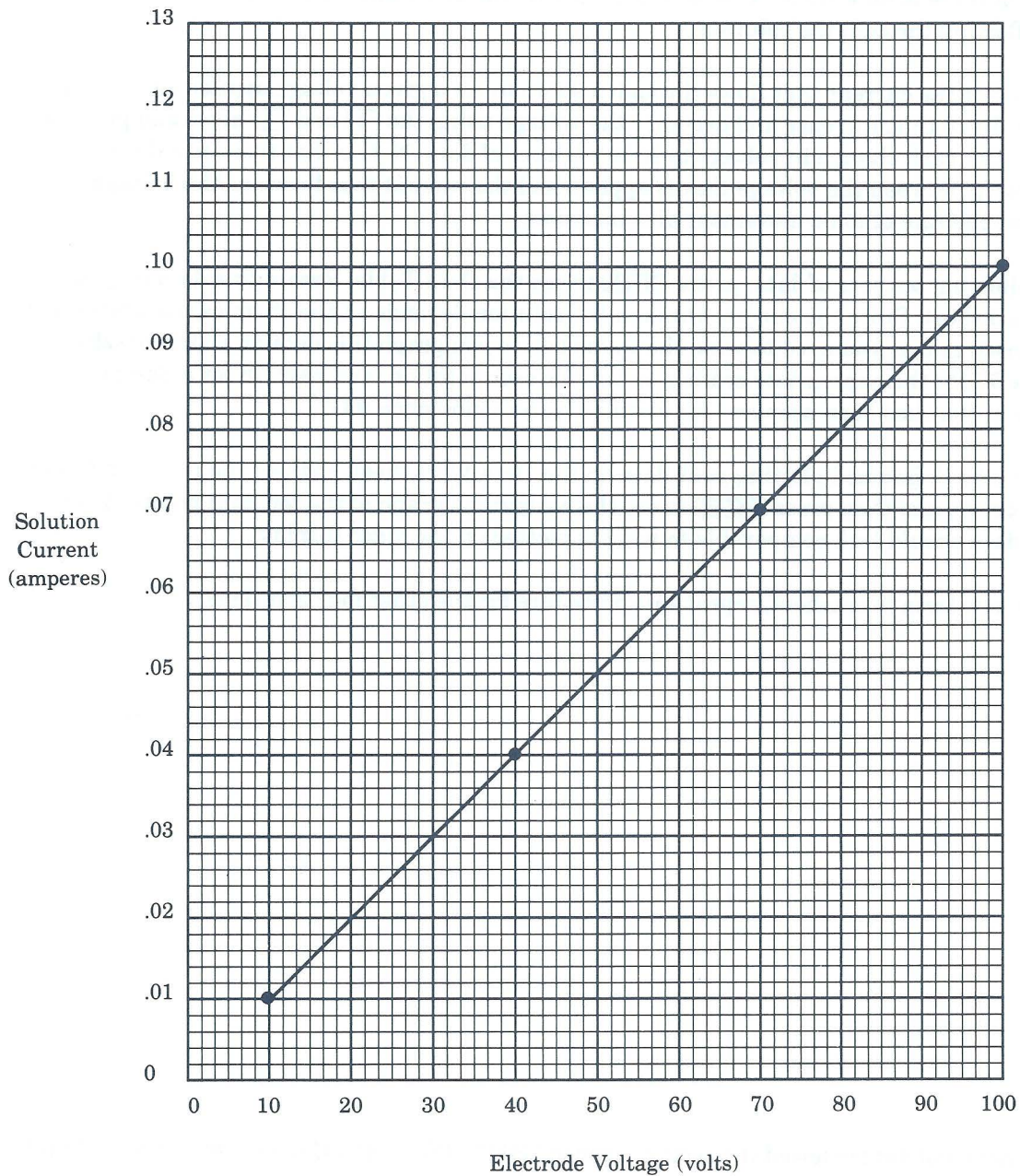

## Conductivity Y-axis values as a function of solution.

Solution	Distilled Water	Sugar Water	Salt Water	Hydrochloric Acid	Magnesium Sulfate
	.13	1.3	23.4	83.2	5.2
	.12	1.2	21.6	76.8	4.8
	.11	1.1	19.8	70.4	4.4
	.1	1	18	64	4
	.09	.9	16.2	57.6	3.6
	.08	.8	14.4	51.2	3.2
	.07	.7	12.6	44.8	2.8
	.06	.6	10.8	38.4	2.4
	.05	.5	9	32	2
	.04	.4	7.2	25.6	1.6
	.03	.3	5.4	19.2	1.2
	.02	.2	3.6	12.8	.8
	.01	.1	1.8	6.4	.4
	0	0	0	0	0

Y-axis values

# Conductivity Data Worksheet

SOLUTION NAME: \_\_\_\_\_

Data Set #	Electrode Voltage (volts)	Solution Current (amperes)
1		
2		
3		
4		

Solution  
Current  
(amperes)

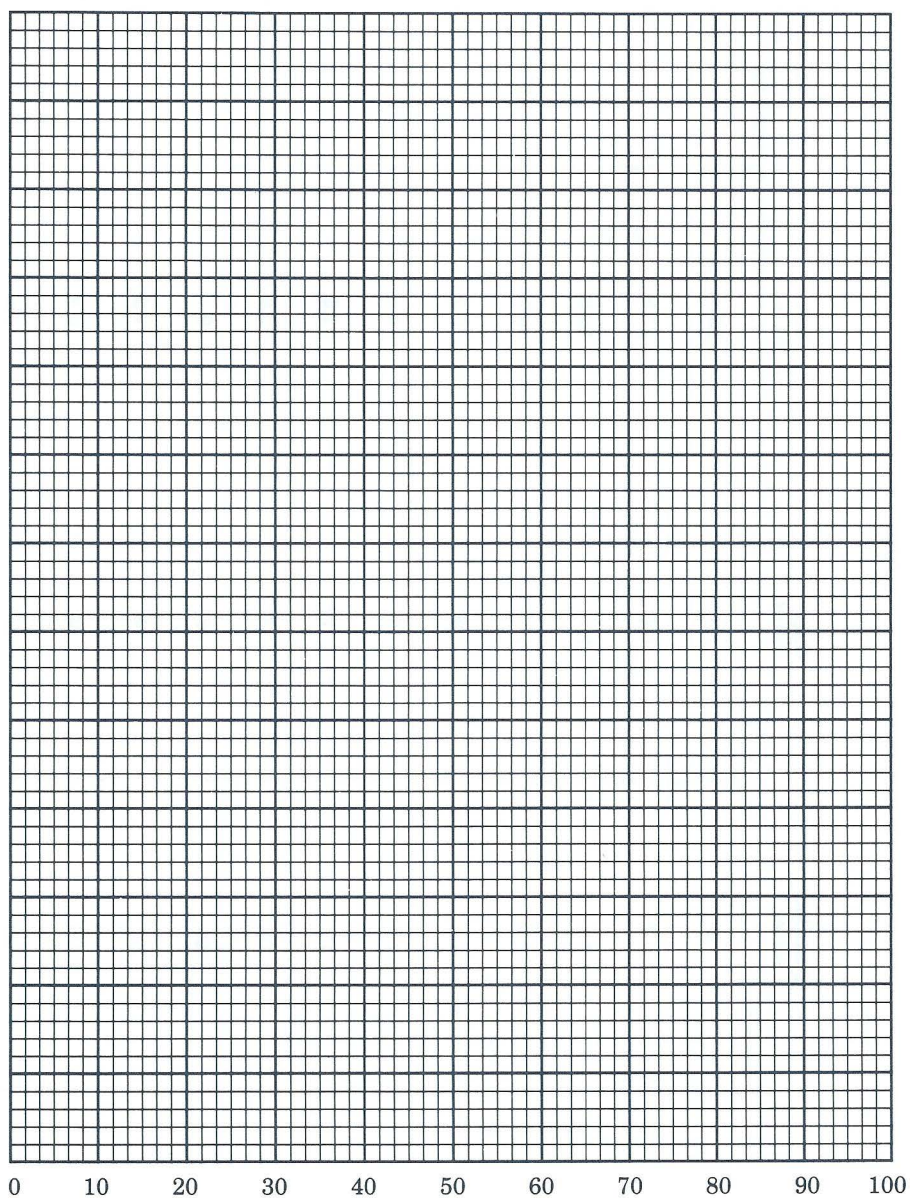

Electrode Voltage (volts)



## Conductivity Conclusions

Now that you have graphed the data, answer the following questions:

1. What is the value of conductivity for each of the five solutions? (Remember that  $C = I/V$ .)

1)  $C = \underline{\quad .001 \quad}$  mhos

2)  $C = \underline{\quad .01 \quad}$  mhos

3)  $C = \underline{\quad .18 \quad}$  mhos

4)  $C = \underline{\quad .64 \quad}$  mhos

5)  $C = \underline{\quad .04 \quad}$  mhos

Notice that it does not matter which of the four data sets is used to calculate the value of conductivity for a given solution. When this relationship between data exists, it is called a linear relationship since the line connecting the data sets will be a straight line.

2. Using the values of conductivity calculated for each solution, calculate the solution current that would be measured if the electrode voltage was set at 50 volts. Now, go back to the experiment and actually measure the solution current that flows when the electrode voltage is equal to 50 volts.

Calculated	Actual
1. $I = \underline{\quad .05 \quad}$ Amperes	$I = \underline{\quad .05 \quad}$ Amperes
2. $I = \underline{\quad 2.5 \quad}$ Amperes	$I = \underline{\quad 2.5 \quad}$ Amperes
3. $I = \underline{\quad 9.0 \quad}$ Amperes	$I = \underline{\quad 9.0 \quad}$ Amperes
4. $I = \underline{\quad 32.0 \quad}$ Amperes	$I = \underline{\quad 32.0 \quad}$ Amperes
5. $I = \underline{\quad 2.0 \quad}$ Amperes	$I = \underline{\quad 2.0 \quad}$ Amperes

They should agree. Do they?       YES





## **Solubility**

**Determination of the quantity of material that will dissolve in a given volume of water.**



## **Solubility Instructional Objectives**

After completing this unit, students will be able to:

1. Define "solute," "solvent," and "solution."
2. Experimentally determine the solubility of a given substance in water.





## Solubility Background Information

A solution is prepared by homogeneously mixing a solid, a liquid, or a gaseous substance with some other solid, liquid or gaseous substance. The substance which occurs in the greatest quantity is said to do the dissolving (and is called the *solvent*), and the less abundant substance is said to be dissolved (and is called the *solute*). The most common example of a solution occurs when a solute such as table salt (NaCl) is placed in a solvent such as water (H<sub>2</sub>O).

You may wish to make sure the students know what it means to homogeneously mix two substances. You may also wish to define “polar solute” for the students.

If we take a beaker of water and add a small amount of salt to it, we will find that the salt begins to dissolve and the concentration of the solution begins to increase. After all the salt has dissolved, the concentration will remain at some constant value which will be determined by the amount of dissolved solute and the volume of the solution. If we keep adding salt to the solution, we will eventually add so much salt that a point will be reached where we will be unable to get any more salt to dissolve in the water. A solution that will not dissolve additional solute is said to be “saturated.”

You may wish to explain to the students that when the solution becomes saturated, they will see the solute begin to pile up on the bottom of the container.

The term “solubility” refers to the amount of a given substance which will dissolve in a given amount of solvent at a given temperature. Temperature has a profound effect upon the quantity of solute which will dissolve, and the rate at which it goes into solution. Typically, you would expect the magnitude of dissolved substance and the rate at which it dissolves to increase as temperature increases.

Students are usually aware that it is easier to get sugar to dissolve in hot tea than in iced tea.

You will be using a computer simulation to experimentally determine the solubility of several substances in water. The computer simulation will measure the amount of a given solute which will dissolve in a given volume of solvent. When no additional solute will dissolve, the solution will become saturated and you will be able to calculate the magnitude of solubility. Solubility is expressed in terms of the number of grams of a substance which can be dissolved per 100 grams of solvent (see the equation below). If you know the quantity of the solvent, and if you can determine the quantity of solute required to produce a saturated solution, you can calculate solubility for the given solute.

Solubility (g/100 grams solvent) =

$$100 \times \frac{\text{quantity of solute required to produce a saturated solution}}{\text{quantity of solvent}}$$

You may wish to give the students practice working with this equation.

## Solubility Summary Quiz

1. A SOLUTION is a homogeneous mixture of a solute and a solvent.
2. The substance which is dissolved is called the SOLUTE.
3. The substance which occurs in the greatest quantity is called the SOLVENT.
4. If additional amounts of a substance added to a solution will not dissolve, the solution is said to be SATURATED.
5. Increasing the temperature of a solution will normally INCREASE the amount of solute which will dissolve.
6. If the following values were experimentally determined, what would the value of solubility be equal to?
  - a) quantity of solvent equals 100 grams
  - b) quantity of solute which will dissolve at 20 C equals 60 grams

Solubility = 60 g/(100 g solvent)

## Solubility Experimental Procedure

Before beginning the Solubility Experimental Procedure, follow the loading instructions and make at least three copies of the Solubility Data Worksheet.\*

In this experiment, you will be presented with a list of three compounds and will determine the solubility of each in water. At the beginning of the experiment, choose the substance you want to work with first and enter the digit associated with that substance. Next choose the quantity of solvent you want to work with by entering any volume of water greater than 100 and less than 1000.

When the experimental apparatus appears, use the  $\downarrow$  key to add solute to the solvent in the cylinder. As you add quantities of solute to the solvent, the amount of dissolved solute will increase. When the solution has become saturated, additional quantities of solute will not dissolve in the solution, but will pile up on the bottom of the cylinder instead.

When the solution has become saturated, record the volume of the solvent and the maximum quantity of solute that dissolved on the Data Worksheet. Then press **(ENTER)** to return to the beginning of the procedure and experimentally determine the solubility of the remaining two compounds.

\*If you have not yet reviewed the section headed "HOW TO USE THE TRS-80 CHEMISTRY LAB, VOLUME I," you should do so at this time.



## Solubility Data Worksheet

Compound	Solvent Quantity (grams)		Solute Quantity (grams)	
	#1	#2	#1	#2
Potassium Bromide				
Sodium Chloride				
Potassium Dichromate				

## Solubility Conclusions

Now that you have collected all the data, answer the following questions:

1. Remembering that solubility is defined as the maximum number of grams of a compound which can be dissolved in 100 g of solvent, calculate the solubility of the three compounds.

Compound	Trial #1	Trial #2
1.	<u>54</u> g/100 g of H <sub>2</sub> O	<u>54</u> g/100 g of H <sub>2</sub> O
2.	<u>36</u> g/100 g of H <sub>2</sub> O	<u>36</u> g/100 g of H <sub>2</sub> O
3.	<u>4</u> g/100 g of H <sub>2</sub> O	<u>4</u> g/100 g of H <sub>2</sub> O

2. Explain why solubility is not a function of solvent volume. *BECAUSE SOLUBILITY IS EXPRESSED AS THE QUANTITY OF SOLUTE WHICH WILL DISSOLVE IN 100g OF SOLVENT.*
  
3. Is the quantity of solute which must be added to the solvent to obtain a saturated solution a function of solvent volume? (In other words, if it takes 50 grams of solute to saturate a given solution, would it take more solute to saturate a larger amount of the same solution?) Why or why not? *YES. SINCE SOLUBILITY IS EXPRESSED AS THE AMOUNT OF SOLUTE WHICH WILL DISSOLVE IN 100g OF SOLVENT, IF THE QUANTITY OF SOLVENT IS INCREASED THE QUANTITY OF SOLUTE NEEDED TO PRODUCE A SATURATED SOLUTION WILL ALSO INCREASE.*



## **Titration**

**Determination of acid concentration by addition of a measured quantity of a known concentration of base.**





## Titration Instructional Objectives

After completing this unit, students will be able to:

1. Define "titration."
2. Experimentally determine the concentration of acid in a solution.
3. Predict the outcome of an experiment.
4. Give a general explanation of what is occurring as a titrimetric analysis is being performed.
5. Define pH.
6. Use experimental procedures which result in low relative error.



## Titration Background Information

Titration is the process of determining the concentration of a substance in solution, by determining what is the smallest amount of a reagent of known concentration that will produce a given effect in reaction with a known volume of the test solution. The given effect that is most often looked for is a change in the color of a special chemical called an indicator. Indicators are usually weak acids or bases which have one color in an acidic solution and another color in a basic solution. Many people are familiar with and have used an indicator called litmus. Litmus dye is red in acidic solutions and is blue in basic solutions.

You may want to demonstrate to the students the effect that various common substances such as lemon juice or hand soap have upon the color of litmus paper.

If we were to take a .1 molar solution of hydrochloric acid (HCl) and add small amounts of a strong basic solution of sodium hydroxide (NaOH) to it, we would find that the solution would become less acidic due to the reaction which tends to neutralize the solution (see the following chemical equation).

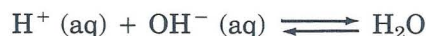

If we continued to add base to the solution, the solution would eventually reach a point which we shall call the "equivalence point." At the equivalence point, the solution is neither acidic nor basic; it is neutral. Adding more NaOH at this point would cause the solution to become basic. If we had placed a small quantity of litmus dye into the solution, we would have seen the color of the solution change from red to blue as the solution went from acidic to basic. The color change occurs when we pass through the equivalence point. If we know the amount of NaOH added to the HCl solution and the molarity of the NaOH, we can calculate the concentration of HCl from the following equation:

$$M_{\text{ACID}} = \frac{V_{\text{BASE}}}{V_{\text{ACID}}} \cdot M_{\text{BASE}}$$

where:

$M_{\text{ACID}}$  = molarity of acid

$M_{\text{BASE}}$  = molarity of base

$V_{\text{ACID}}$  = volume of acid test solution

$V_{\text{BASE}}$  = volume of base added

Suppose that instead of .1M solution of HCl, we had used a .1M solution of sulfuric acid ( $\text{H}_2\text{SO}_4$ ) as the acid test solution. Using the same solution of NaOH as in the previous example, we would have found that it required twice as much base to neutralize the acid and reach the equivalence point. The reason for this is illustrated with the following two chemical equations.





From these equations we can see that  $\text{H}_2\text{SO}_4$  has twice the chemical capacity of  $\text{HCl}$  when reacting with  $\text{NaOH}$ . An alternative method of expressing concentration is based upon a weight system known as equivalent weights. The equivalent weight is that weight of a substance that loses, or gains, 1 electron in an oxidation-reduction reaction. A .1M solution of  $\text{HCl}$  would be equal to a .1-normal (.1N) solution of  $\text{HCl}$  when reacted with  $\text{NaOH}$ . However, a .1M solution of  $\text{H}_2\text{SO}_4$  would be equal to a .2N solution of  $\text{H}_2\text{SO}_4$  when reacted with  $\text{NaOH}$ . If we know the normality and the amount of basic solution being used to titrate an acidic solution, we can calculate the concentration of the acid from the following formula.

$$N_{\text{ACID}} = \frac{V_{\text{BASE}}}{V_{\text{ACID}}} \cdot N_{\text{BASE}}$$

where:

$N_{\text{ACID}}$  = normality of acid

$N_{\text{BASE}}$  = normality of base

$V_{\text{ACID}}$  = volume of acid test solution

$V_{\text{BASE}}$  = volume of base added

You may wish to give the students some experience working with these equations.

The acidity of aqueous solutions depends upon the concentration of hydrogen ions that are in the solution. To express the acidity of a solution in terms of convenient numerical figures, the pH scale has been developed. The values on the pH scale, which range between 0 and 14, are derived by the following equation.

$$\text{pH} = -\log(\text{H}^+)$$

where

$(\text{H}^+)$  =  $\text{H}^+$  ion concentration in moles/liter

If the students have not been introduced to the log table, this might be a good time to teach them how to use one.

At the equivalence point of a solution, the pH is equal to 7 and the solution is said to be neutral. As a solution becomes increasingly acidic, the pH becomes less than 7. As a solution becomes increasingly basic, the pH becomes greater than 7.

Be sure the students know they should run at least six labs for each solution before going on to check their data against the exact molarity provided by the program. Once they see the exact molarity for an unknown solution, they cannot titrate that unknown again.

## Titration Summary Quiz

1. Titration is the process of determining the CONCENTRATION of a substance in a solution.
2. LITMUS dye is a common indicator which is used to tell whether a solution is acidic or basic.
3. Litmus dye is RED in acidic solutions and BLUE in basic solutions.
4. A solution which has reached the equivalence point is NEUTRAL.
5. Write the equation that allows the calculation of concentration from experimental data.

$$\text{Molarity of acid} = \frac{V_{\text{BASE}}}{V_{\text{ACID}}} \times M_{\text{BASE}}$$

6. At the equivalence point, the pH of a solution is equal to 7.
7. Solutions having a pH less than 7 are said to be ACIDIC.
8. Solutions having a pH greater than 7 are said to be BASIC.

# Titration Experimental Procedure

Before beginning the Titration Experimental Procedure, follow the loading instructions and make at least two copies of the Titration Data Worksheet.\*

In this experiment, you will determine the concentration of acid in an unknown solution. At the beginning of the experiment, choose the concentration of the base solution to be used in the titration by entering the digit associated with that concentration. Next choose the quantity of unknown acid solution by entering a number that is more than 10 and less than 200.

Remember that the most accurate measurements will be made by using a low concentration of base solution and a large volume of unknown acid solution. However, many of the unknown acid solutions will not reach the equivalence point using the maximum amount of base (three burets) at the lowest concentration. In other words, you may run out of base if you choose to use a large volume of test solution and a concentration of .001 for the base solution. You will then have to repeat the procedure using a stronger base or less test solution. So you may want to begin the procedure with a high concentration of base and a small amount of acid, and then repeat the procedure several times with lower concentration of base and larger volumes of acid to improve the accuracy of the results.

When the experimental apparatus appears, you will perform the titration by using the  $\downarrow$  key to add drops of base solution to the unknown acid solution (test solution). When the equivalence point has been reached, the test solution undergoes a change in color. This means that the acid solution has been neutralized by the base solution. The change in color represents the change that would have occurred if an indicator substance (like litmus dye) had been placed in the acid solution.

After completing the titration, press **ENTER** to continue and enter the data from the experiment into the appropriate lines on the screen. The computer will correct your responses if you have forgotten the volume of acid and the molarity of base and will fill in the value for the volume of base. Next, calculate the molarity of acid using the equation at the bottom of the screen and enter the results.\*\*

When you have recorded all the data from this procedure on your Data Worksheet (see page 99 for a Sample Data Worksheet), follow the instructions to run another lab using the same acid solution. Repeat the procedure using the same acid solution, lowering the concentration of base or increasing the volume of acid to obtain more accurate data.

When you have repeated the experiment five times and have completed the Data Worksheet for the first test solution, press **ENTER** to see the exact molarity of the unknown acid solution. Record the exact molarity on your Data Worksheet, and press **ENTER** to start a new titration on a new Data Worksheet.

\*If you have not yet reviewed the section headed "HOW TO USE THE TRS-80 CHEMISTRY LAB, VOLUME I," you should do so at this time.

\*\*Five significant digits can be entered, but the answer displayed will be rounded to four digits. For greatest accuracy, the student should record his or her answer, not the rounded answer, on the Data Worksheet.



## Titration Sample Data Worksheet

Unknown Solution # \_\_\_\_\_

Titration Number	Molarity of Base	Volume of Acid	Volume of Base	Experimental Molarity of Acid	Actual Molarity of Acid	Absolute Error	Relative Error
1	1	25	4	.16	.197	.037	18.7%
2	1	125	24	.192		.005	2.5%
3	.1	25	49	.196		.001	.5%
4	.1	75	147	.196		.001	.5%
5	.1	183	360	.1967		.0003	.15%
6	.01	25	492	.1968		.0002	.1%

Average Experimental Molarity of Acid = .1895

Absolute Error (Average - Actual Molarity) = .0075

Relative Error (Absolute Error / Actual Molarity · 100%) = 3.8%

Best Experimental Molarity of Acid = .1968

Absolute Error (Best - Actual Molarity) = .0002

Least Relative Error (Absolute Error / Actual Molarity · 100%) = .1%



## Titration Data Worksheet

Unknown Solution # \_\_\_\_\_

Titration Number	Molarity of Base	Volume of Acid	Volume of Base	Experimental Molarity of Acid	Actual Molarity of Acid	Absolute Error	Relative Error
1							
2							
3							
4							
5							
6							

Average Experimental Molarity of Acid =  
 Absolute Error (Average - Actual Molarity) =  
 Relative Error (Absolute Error / Actual Molarity · 100%) =

Best Experimental Molarity of Acid =  
 Absolute Error (Best - Actual Molarity) =  
 Least Relative Error (Absolute Error / Actual Molarity · 100%) =

## Titration Conclusions

After you have finished titrating all five solutions, answer the following questions.

1. Calculate the absolute error for each of the five solutions. Then express it as a percentage relative to the actual value, where:

$$\text{Absolute error} = \text{actual value} - \text{calculated value}$$

$$\text{Relative error} = \frac{\text{absolute error}}{\text{actual value}} \cdot 100\%$$

Record these values in the appropriate place on the experimental worksheet.

2. The highest degree of accuracy occurs when a moderate amount of a relatively weak base is used. Explain why very small amounts of a very strong base can lead to large values of relative error. *IF THE BASE IS VERY STRONG, ONE DROP COULD CAUSE THE SOLUTION TO GO FROM ACIDIC, THROUGH THE EQUIVALENCE POINT, AND BECOME BASIC.*



## **APPENDICES**





## Appendix I:

### MAKING A BACKUP COPY OF THE MODEL III TRS-80 CHEMISTRY LAB, VOLUME I DISKETTE

It is good practice to make a backup copy of the Model III TRS-80 Chemistry Lab, Volume I program diskette to use with your students. The original diskette supplied with the package should be stored to protect it from damage.

The Model III TRS-80 Chemistry Lab, Volume I diskette lets you make three backup copies. Should your diskette be damaged before all three backups have been made, Radio Shack will replace the diskette with a Chemistry Lab, Volume I diskette that has the same number of backups remaining. Just send your name, address, and the damaged diskette to the address below:

Educational Software Librarian  
Radio Shack Education Division  
1400 One Tandy Center  
Fort Worth, TX 76102

(Please specify that you want a Model III diskette as replacement.)

Be sure to leave the square notch in the Model III Chemistry Lab diskette UNCOVERED while you are making a backup copy. (Backup instructions for some other Radio Shack programs may suggest that you cover the notch.)

To make a backup copy, follow the steps below.

#### Model III Two-Drive System

1. Turn on the computer. (The On/Off switch is under the right side of the keyboard.)
2. After the red lights on the disk drives go off, insert a new, blank diskette in Drive 1 (the top drive) with the square notch to the left and the label facing up, and close the door.
3. Insert the program diskette in Drive 0 (the bottom drive) with the UNCOVERED notch to the left\* and the label facing up, and close the door.
4. Press the orange Reset button.

5. When the screen shows:

You type:

Enter Date (MM/DD/YY)?

09/01/83 ENTER

(Example for Sept. 1, 1983)

Enter Time (HH:MM:SS)?

Press ENTER

TRSDOS Ready

BACKUP ENTER

SOURCE Drive Number?

0 ENTER

\*See note at top of this page.

**DESTINATION Drive Number?**      **1** **ENTER**

**SOURCE Disk Master Password?**      **P A S S W O R D** **ENTER**

The drives will come on and the computer will proceed to make the backup. If, after the drives stop spinning, the screen shows:

**\*\*Backup Complete\*\***

then remove the original program diskette from Drive 0 and store it in a safe place. You can now place your backup copy in Drive 0 and continue working with the program.

If, after the drives stop spinning, the screen shows an error message of any kind, or does not say **Backup Complete**, then press the orange Reset button and go back to Step 5. If an error still occurs, then get a new blank diskette or bulk erase the diskette you have been using as destination disk. Then insert the blank diskette in Drive 1, press the Reset button, and go to Step 5.

### Model III One-Drive System

1. Turn on the computer. (The On/Off switch is under the right side of the keyboard.)
2. After the red light on the disk drive goes off, insert the program diskette in the disk drive with the UNCOVERED notch to the left\* and the label facing up. Close the door.
3. Press the orange Reset button.
4. When the screen shows:      You type:

**Enter Date (MM/DD/YY)?**      **0 9 / 0 1 / 8 3** **ENTER**  
(Example for Sept. 1, 1983)

**Enter Time (HH:MM:SS)?**      Press **ENTER**

**TRSDOS Ready**      **B A C K U P** **ENTER**

**SOURCE Drive Number?**      **0** **ENTER**

**DESTINATION Drive Number?**      **0** **ENTER**

**SOURCE Disk Master Password?**      **P A S S W O R D** **ENTER**

**Insert SOURCE Diskette**      Press **ENTER**  
**ENTER**

**Insert DESTINATION Diskette**  
**ENTER**

After the red light on the disk drive goes off, remove the program diskette and insert a new, blank diskette with the uncovered notch to the left and the label facing up. Close the door and press **ENTER**.

\*See note at the top of page 105.

**Insert SOURCE Diskette**

**ENTER**

Continue to switch back and forth between the program diskette (SOURCE diskette, notch uncovered) and the new diskette (DESTINATION diskette, notch uncovered) as instructed on the screen. Do not open the disk drive door while the red light is on.

If the screen shows:

**\*\*Backup Complete\*\***

**Insert SYSTEM Diskette** **ENTER**

then press **ENTER**. You can now continue working with the program using the backup copy currently in the disk drive. Be sure to store the original program diskette in a safe place.

If the screen shows an error message of any kind or does not say **Backup Complete**, then put the program diskette back in the drive, press the Reset button, and go to Step 4. If an error still occurs, get a new blank diskette or bulk erase the diskette you have been using as a destination diskette. Put the program diskette back in the drive, press the Reset button, and go to Step 4.





## Appendix II: MAKING A BACKUP COPY OF THE MODEL III, MODEL I, OR COLOR COMPUTER TRS-80 CHEMISTRY LAB, VOLUME I TAPE

It is good practice to make a backup copy of TRS-80 Chemistry Lab program cassettes to use with your students. The original cassette supplied with the program should be stored to protect it from damage. To make a backup copy, follow the steps below.

### I. GETTING READY

#### A. If the computer is off:

1. Model III: Follow Step 1 on page 8 of this manual.  
Color Computer: Follow Steps 1 and 2 on page 10 of this manual.  
Model I: Follow Step 1 on page 119 of this manual.
2. Skip to II.

#### B. If the computer is on and a TRS-80 Chemistry Lab is loaded:

1. If a TRS-80 Chemistry Lab is running, use the termination code **(SHIFT) (T)** and wait for the READY prompt.
2. When the READY or OK prompt is showing, skip to III.

#### C. If the computer is on and a program other than a TRS-80 Chemistry Lab is loaded:

1. If the program is running, terminate the program by using the **(BREAK)** key or any special code that may apply to that particular program.
2. When the READY or OK prompt appears, type **(N)(E)(W) (ENTER)** .
3. When the READY or OK prompt appears again, you are ready to load a TRS-80 Chemistry Lab program.

### II. LOADING A TRS-80 CHEMISTRY LAB PROGRAM

Model III: Follow Steps 2 through 8 on page 8 of this manual.

Color Computer: Follow Steps 3 through 6 on page 10 of this manual.

Model I: Follow Steps 2 through 7 on page 119 of this manual.

### III. MAKING A NEW COPY OF THE PROGRAM TAPE

- A. Place a blank cassette in the recorder. (Use only TRS-80 C-20 certified cassettes, or other digital quality cassettes.)
- B. Make sure the tape is rewound. Use the "FAST FORWARD" button if necessary to advance the tape past the leader.

- C. Press "PLAY" and "RECORD" simultaneously.
- D. Type **C** **S** **A** **V** **E** **"** **K** **"** and press **ENTER** .\*
- E. Wait for the READY or "OK" prompt to reappear. (The recorder will start to run and will stop automatically when the prompt appears.)
- F. Rewind the cassette.
- G. Remove and label the cassette which now contains a new copy of a TRS-80 Chemistry Lab program.

\*Use the first letter of the program filename when backing up each tape. For instance, use **"** **K** **"** for Kinetic Theory, **"** **C** **"** for "Charles' Law," etc.

## **Appendix III: PLANNING YOUR APPLICATION**

### **Appropriate Applications**

There seems to be an endless variety of ways to use a computer with students. Some that are appropriate for use with the Radio Shack TRS-80 Chemistry Lab, Volume I are:

- A number of computers or "student stations" are placed in a special room or learning lab, where students attend scheduled sessions. A special teacher or teacher aide may be in charge of the lab to help students load and run specified programs, to record scores, and to help with the operation of the system. This scheduled approach provides maximum computer utilization and makes possible the lowest obtainable cost per hour of usage.
- Individual computers are placed in regular classrooms, where they are available to the teacher for use with individual students at the teacher's discretion. This use is becoming more common with the new microcomputers due to the low cost for each system and due to the portability of these systems (no special telephone lines or modems are required).
- Individual computers are loaned or "checked out" to students to take home and use to solve special assignments, or as an incentive for individual studies.
- Computers are provided for general student use in a library — during school, or after hours — for periods of time that a student can reserve in advance.
- Computers are provided for use by teachers at a central service center or audio-visual library. A teacher can check out a system for use in the classroom. Again, the portability of the microcomputer and its freedom from telephone communication lines makes this use convenient.

There are numerous combinations of these and other uses that are possible. Your own unique circumstances — number of students, or number of computers available — will influence your plans. The following information is designed to help you in planning for the use of microcomputers in your school, and to give you the benefit of others' experience in developing a realistic and satisfactory installation in your own facility.

#### **Saving and Loading Programs: Cassettes vs. Diskettes**

The audio cassette is the least expensive method of saving and loading programs for a microcomputer. The basic version of almost all microcomputers includes a cassette recorder for this purpose. Because of its reasonable cost, the cassette recorder merits consideration for use as a program storing device in the classroom; it makes possible the lowest obtainable cost per hour of student operation.

Under proper conditions, the cassette recorder can be a satisfactory storage medium for use with microcomputers. However, there are some special considerations that should be given before deciding on the cassette for program storage over another medium such as the diskette. First, the quality of cassette tapes used for storage of computer programs (digital information) is more critical than for audio use. In addition, static electricity can damage information



recorded on cassettes in a carpeted area, or in a dry climate. And, since a program stored on a cassette takes longer to load into a microcomputer than a similar program stored on a diskette, operational considerations may make the use of the cassette recorder for loading programs unrealistic in the classroom setting.

### **A Radio Shack Network System**

A Radio Shack Network 2 or Network 3 system is a low-cost alternative to cassette tapes for saving and loading programs for the classroom. The Network 2 and Network 3 Controllers allow from one to sixteen non-disk TRS-80's to be connected to one TRS-80 disk system.

The Network 2 Controller allows the teacher to load instructional programs into the TRS-80 student stations from the central disk system conveniently and reliably. All sixteen student stations can be loaded simultaneously, or any combination of stations can be loaded at a time.

The Network 3 Controller allows students at individual student stations to load programs from the host system disk into their own stations and to use the host's printer without teacher supervision. Network 3 allows all sixteen student stations in the network system to load the same or different programs simultaneously. In addition to working with the TRS-80 Chemistry Lab, Volume I program, the Network 3 system works with many of Radio Shack's other software products.

### **A Second Alternative: A Disk Drive for Each Student Station**

Although this increases the cost per student station, this is still considerably less expensive than a conventional timesharing system, and there are several advantages over a cassette. First, several programs can be stored on a single diskette and loaded into the computer conveniently by merely typing the program name to be loaded. In addition, no rewinding or tape positioning using an index counter is required with the diskette. And, most important, programs can be loaded from a diskette many times faster than from tape, making the diskette much more desirable from an operational standpoint. A program that requires a couple of minutes to load from a cassette can be loaded in a few seconds from a diskette. Finally, remember that a method of loading programs is important when the TRS-80 is used as a medium of instruction with programs such as Matrices, Determinants, and Simultaneous Equations. However, where the TRS-80 is used as an object of instruction for teaching about the computer, the ability to load and save programs may not be as important. Introduction to BASIC, the first part of the Radio Shack Computer Education Series, does not require that any prepared programs be loaded for instruction or demonstration. All program examples are brief and are designed to be entered by the student using the keyboard. (One section of this course does teach the proper use of the recorder for saving and loading programs.)

## **Choosing a Location: Environmental Considerations**

Large computer systems require temperature- and humidity-controlled environments with air filtration systems to eliminate dust and other contaminants. Fortunately, the TRS-80 is not so demanding.

At the same time, certain considerations in the location you choose for your microcomputer will have a direct effect upon its operation and reliability. For best results, you should keep these in mind when choosing the location.

## Static Electricity

In dry climates and certain seasons, you can walk across a carpet and feel the static discharge when you touch a metal object. Under some climatic conditions, even your clothing can build up this kind of charge, normally too small for you to feel. These static charges can damage magnetically-stored computer data. Larger charges can even wipe out your computer's memory or cause it to appear to "lock up." If you are in a part of the country where humidity is lower than about 40%, be wary! The ideal humidity level for the operation of a computer is 50% or above. The safest bet is to use a non-carpeted room for your computer. An anti-static floor mat at the computer operator's position can also help.

This is a rather infrequent problem in actual practice, so rest assured we are not trying to imply that you will have this or any of the other problems we have mentioned. We are simply explaining why choice of your installation location should be given consideration and what to do just in case you do encounter a problem.

## Power Line Interference

Any complex electronic equipment is sensitive to power line conditions affecting the voltage and current coming out of your wall socket. Computers are probably more sensitive than other electronics because the loss of even one bit (one tiny electrical charge) of information can cause a program to "bomb out" or a data file to be lost. This is rarely a problem unless you are operating in an environment which shares its power line with a lot of electrical machinery, particularly electrical motors. Yet you might experience trouble if an appliance or office machine has a defective switch which arcs when turned on or off. If this happens, you will have to (1) repair the appliance, or (2) isolate the power going to the computer by either (a) connecting the computer and peripherals to a separate line or (b) using a line filter (TRS-80 Models II, III, and 16 have built-in line filters). In a severe case, both (a) and (b) may be required. "Brownouts" (periodic drops in line voltage to unusually low levels) or power line "spikes" (transient surges of very large voltage levels lasting only a fraction of a second) may require the addition to your system of a "constant voltage transformer."

Power line problems are rare and many times can be avoided by proper choice of installation location for your computer system. The more complex the system, the more consideration you should give to your installation.



**Appendix IV:**  
**SPECIAL INFORMATION FOR TRS-80 MODEL I USERS**





## How to Get the Model I Software

The Model III/(Model I) TRS-80 Chemistry Lab, Volume I package (Cat. No. 26-2609) contains a diskette for use with the Model III 32K or 48K disk system, and a 1500 Baud cassette tape for use with the Model III 16K tape system.

To get free replacement software for use with a Model I 32K or 48K disk system and/or a Model I 16K tape system, just send your name, address, and the Model III software that you want to replace to this address:

Educational Software Librarian  
Radio Shack Education Division  
1400 One Tandy Center  
Fort Worth, TX 76102

# LOADING THE MODEL I TRS-80 CHEMISTRY LAB, VOLUME I

## TRS-80 Model I Disk System

1. Turn on the expansion interface, video display, and disk drives.
2. Place the program diskette with the square notch up and the label to the right in Drive 0 (Drive 0 is the disk drive closest to the expansion interface on the cable), and close the door.
3. Turn on the keyboard by pushing in the power button located on the back to the left of the power jack.
4. When **DOS READY** appears on the screen,\* type **B A S I C** and press **ENTER**.
5. When **HOW MANY FILES?** appears on the screen, press **ENTER**. When **MEMORY SIZE?** appears on the screen, press **ENTER** again.
6. When the **READY** prompt appears, type **R U N " K I N E T I C "** and press **ENTER**.\*\* You'll see the title screen appear on the video display.

To begin working with Kinetic Theory, turn to page 11.

\*If your Model I computer is equipped with a lower-case modification, you may want to enable the lower-case driver when **DOS READY** first appears on the screen.

\*\*To run a program other than Kinetic Theory, see the note on page 9.

## TRS-80 Model I Tape System\*

1. Turn on the video display by pressing in the power button. Next, turn on the keyboard by pushing in the power button on the back.
2. Place the Model I program cassette that you want to use in the cassette recorder. For this demonstration, use the cassette labeled "Kinetic Theory."
3. Set the volume level of the cassette recorder between 5 and 7.
4. Press "REWIND." When the cassette is rewound, press "STOP," then press "PLAY."
5. When **MEMORY SIZE?** appears on the video display, press **ENTER**.
6. Type **C L O A D** and press **ENTER**. (If the program is loading properly, two asterisks will appear in the upper right corner of the screen. The right asterisk will blink.)\*\*
7. When the **READY** prompt appears on the screen, press the "STOP" button, then press "REWIND" to rewind the tape on the recorder. Next, remove the tape and replace it in the cassette holder to protect it from damage.
8. Type **R U N** and press **ENTER**. You'll see the title screen appear on the video display.

To begin working with Kinetic Theory, turn to page 11.

\*Do not use the lower-case driver (UCLBAS) with the cassette version of TRS-80 Chemistry Lab, Volume I.

\*\* If the asterisks do not appear after several seconds:

- press "STOP"
- turn the volume a little higher
- press the Reset button at the rear of the Model I keyboard
- repeat the instructions from Step 4.

If the asterisks appear, but the right one does not blink:

- press "STOP"
- turn the volume a little lower
- press the Reset button at the rear of the Model I keyboard
- repeat the instructions from Step 4.



# MAKING A BACKUP COPY OF THE MODEL I TRS-80 CHEMISTRY LAB, VOLUME I DISKETTE

It is good practice to make a backup copy of the Model I TRS-80 Chemistry Lab, Volume I program diskette to use with your students. The original Model I diskette should be stored to protect it from damage.

## Model I Two-Drive System

1. Turn on everything except the TRS-80 keyboard. If this is the first time you've ever used the Radio Shack Disk System, refer to the Disk Operating System/Disk BASIC manual for detailed instructions.
2. Insert a new, blank diskette in Drive 1 (second from the expansion interface on the cable) with the square notch up and the label to the right, and close the door.
3. Place an adhesive tab (provided with new diskettes) over the square notch in the Model I TRS-80 Chemistry Lab, Volume I program diskette. If you do not have any tabs, use a small piece of cellophane tape.
4. Insert the program diskette in Drive 0 (closest to the expansion interface on the cable) with the covered notch up and the label to the right, and close the door.
5. Turn on the TRS-80 keyboard. (The On/Off button is on the right rear of the keyboard.)

6. When the screen shows:

You type:

**DOS READY**

**B A C K U P** **ENTER**

**SOURCE DRIVE NUMBER?**

**0** **ENTER**

**DESTINATION DRIVE NUMBER?**

**1** **ENTER**

**BACKUP DATE (MM/DD/YY)?**

**09/01/83** **ENTER**

(Example for September 1, 1983)

The drives will come on and the computer will proceed to make the backup. If, after the drives stop spinning, the screen shows:

**BACKUP COMPLETE**

**HIT <ENTER> TO CONTINUE**

then press **ENTER**.

If, after the drives stop spinning, the screen shows an error message of any kind, or does not say **BACKUP COMPLETE**, then press the Reset button and go back to Step 6. If an error still occurs, then get a new blank diskette or bulk erase the diskette you have been using as destination diskette. Then insert the blank diskette in Drive 1, press **ENTER**, and go to Step 6.

## Model I One-Drive System

1. Turn on the expansion interface, disk drives, and video display. If this is the first time you've ever used the Radio Shack Disk System, refer to the Disk Operating System/Disk BASIC manual for detailed instructions.
2. Place an adhesive tab (provided with new diskettes) over the square notch in the TRS-80 Chemistry Lab, Volume I program diskette. If you do not have any tabs, use a small piece of cellophane tape.
3. Insert the program diskette in the disk drive with the covered notch up and the label to the right. Close the door.
4. Turn on the TRS-80 keyboard. (The On/Off button is on the right rear of the keyboard.)

5. When the screen shows:

You type:

**DOS READY**

**B A C K U P ENTER**

**SOURCE DRIVE NUMBER?**

**0 ENTER**

**DESTINATION DRIVE NUMBER?**

**0 ENTER**

**BACKUP DATE (MM/DD/YY)?**

**09 / 01 / 83 ENTER**

(Example for Sept. 1, 1983)

**INSERT SOURCE DISK**

Press **ENTER**

**INSERT DESTINATION DISK**

After the red light on the disk drive goes off, remove the program diskette and insert a new, blank diskette with the uncovered notch up and the label to the right. Close the door and press **ENTER**.

**INSERT SOURCE DISK**

Continue to switch back and forth between the program diskette (SOURCE DISK, notch covered) and the new diskette (DESTINATION DISK, notch uncovered) as instructed on the screen. Do not open the disk drive door while the red light is on.

If the screen shows:

**BACKUP COMPLETE  
HIT <ENTER> TO CONTINUE**

then press **ENTER**.

If the screen shows an error message of any kind, or does not say **BACKUP COMPLETE**, then put the program diskette back in the drive, press the Reset button, and go back to Step 5. If an error still occurs, get a new blank diskette or bulk erase the diskette you have been using as destination disk. Put the program diskette back in the drive, press **ENTER**, and go to Step 5.







**RADIO SHACK**  **A DIVISION OF TANDY CORPORATION**

**U.S.A.: FORT WORTH, TEXAS 76102**  
**CANADA: BARRIE, ONTARIO L4M 4W5**

---

**TANDY CORPORATION**

---

**AUSTRALIA**

91 KURRAJONG ROAD  
MOUNT DRUITT, N.S.W. 2770

---

**BELGIUM**

PARC INDUSTRIEL DE NANINNE  
5140 NANINNE

---

**U. K.**

BILSTON ROAD WEDNESBURY  
WEST MIDLANDS WS10 7JN









# TRS-80<sup>®</sup> Chemistry Lab, Volume I

Color  
Computer

Cat. No.  
26-2626

**TRS-80® Chemistry Lab, Volume I**  
**Boyle's Law**

COLOR BASIC  
Min. RAM 16K  
OK CLOAD  
OK RUN

TRS-80®



TRS-80®

© 1982, RICHARD C. HALLGREN  
ALL RIGHTS RESERVED.  
LICENSED TO TANDY CORPORATION.

Cat. No.  
26-2626

**TRS-80® Chemistry Lab, Volume I**  
**Solubility**

COLOR BASIC  
Min. RAM 16K  
OK CLOAD  
OK RUN

TRS-80®



TRS-80®

© 1982, RICHARD C. HALLGREN  
ALL RIGHTS RESERVED.  
LICENSED TO TANDY CORPORATION.

Cat. No.  
26-2626

**TRS-80® Chemistry Lab, Volume I**  
**Kinetic Theory**

COLOR BASIC  
Min. RAM 16K  
OK CLOAD  
OK RUN

TRS-80®



TRS-80®

© 1982, RICHARD C. HALLGREN  
ALL RIGHTS RESERVED.  
LICENSED TO TANDY CORPORATION.

Cat. No.  
26-2626



**TRS-80® Chemistry Lab, Volume I**  
**Conductivity**

COLOR BASIC

Min. RAM 16K

OK CLOAD

OK RUN

TRS-80®

TRS-80®

© 1982, RICHARD C. HALLGREN  
ALL RIGHTS RESERVED.  
LICENSED TO TANDY CORPORATION.

Cat. No.  
26-2626

**TRS-80® Chemistry Lab, Volume I**  
**Titration**

COLOR BASIC

Min. RAM 16K

OK CLOAD

OK RUN

TRS-80®

TRS-80®

© 1982, RICHARD C. HALLGREN  
ALL RIGHTS RESERVED.  
LICENSED TO TANDY CORPORATION.

Cat. No.  
26-2626

**TRS-80® Chemistry Lab, Volume I**  
**Charles' Law**

COLOR BASIC

Min. RAM 16K

OK CLOAD

OK RUN

TRS-80®

TRS-80®

© 1982, RICHARD C. HALLGREN  
ALL RIGHTS RESERVED.  
LICENSED TO TANDY CORPORATION.

Cat. No.  
26-2626